

Size: 36 x 48	Layers This Sheet: Arching Contour Blocks Border Braces/RoundHole	Neck Body Notes
	Print Out Dimensions Reference Lines Hardware	Strings TitleBlock RoundHole

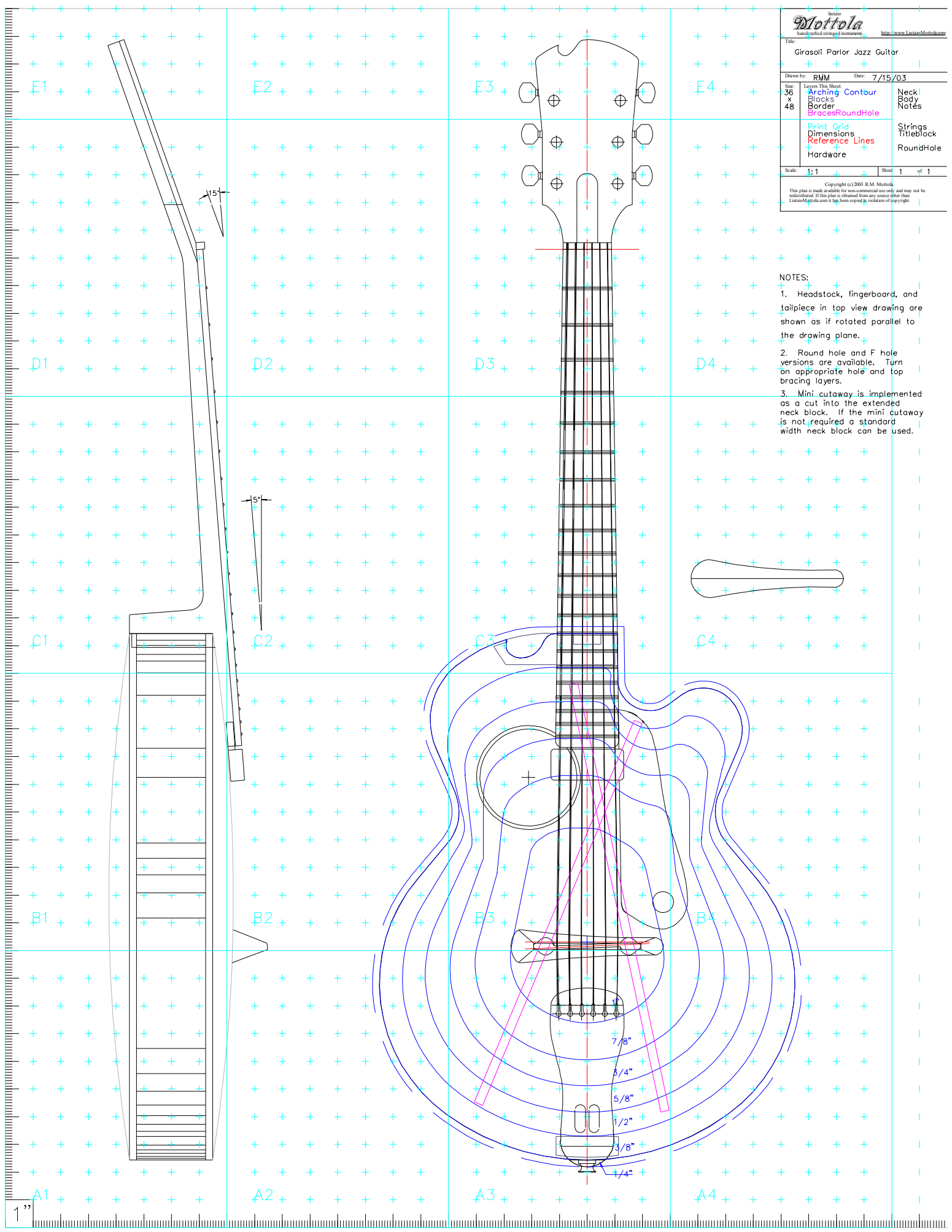

NOTES:

1. Headstock, fingerboard, and tailpiece in top view drawing are shown as if rotated parallel to the drawing plane.
2. Round hole and F hole versions are available. Turn on appropriate hole and top bracing layers.
3. Mini cutaway is implemented as a cut into the extended neck block. If the mini cutaway is not required a standard width neck block can be used.

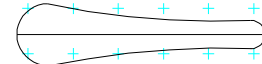

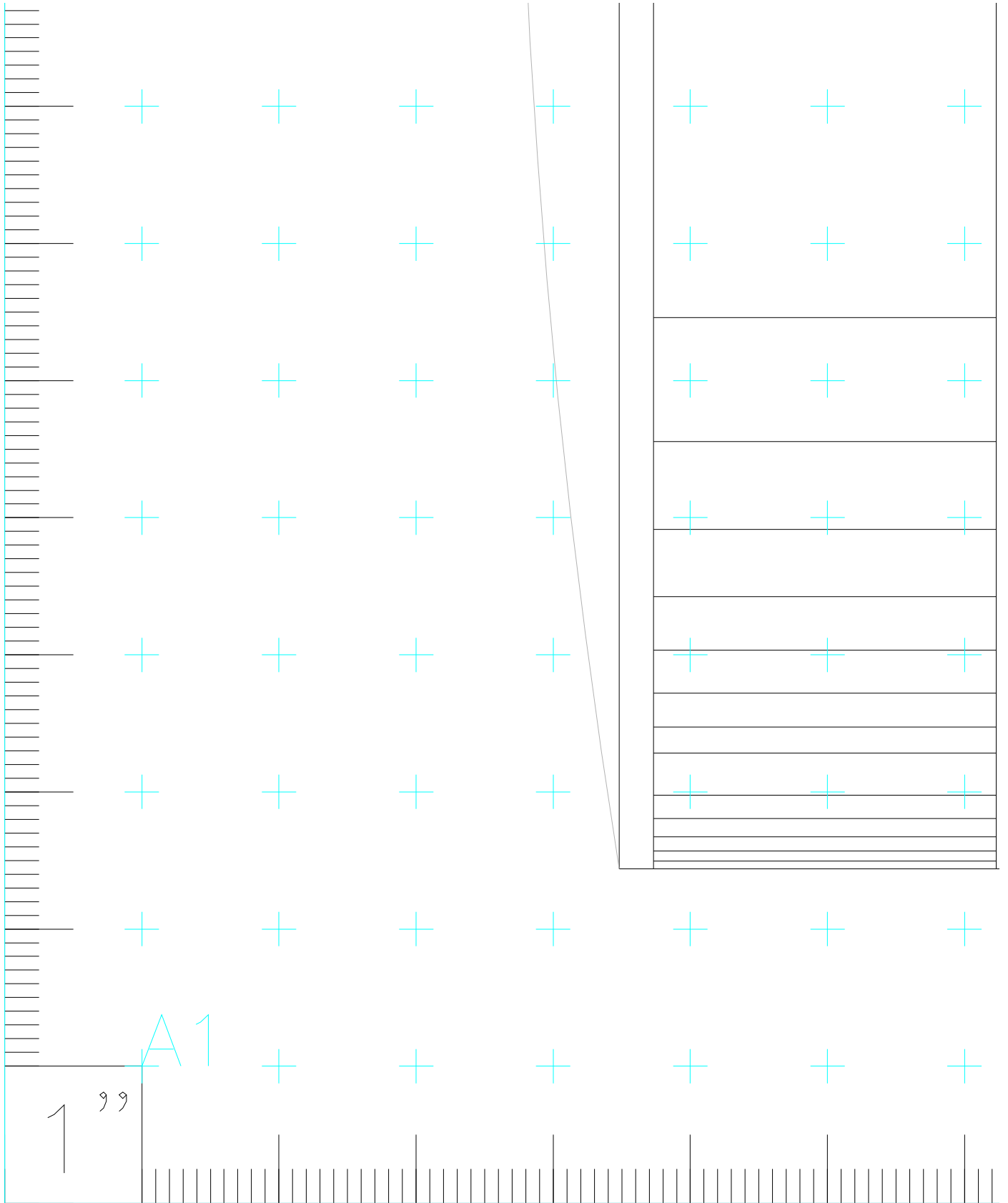

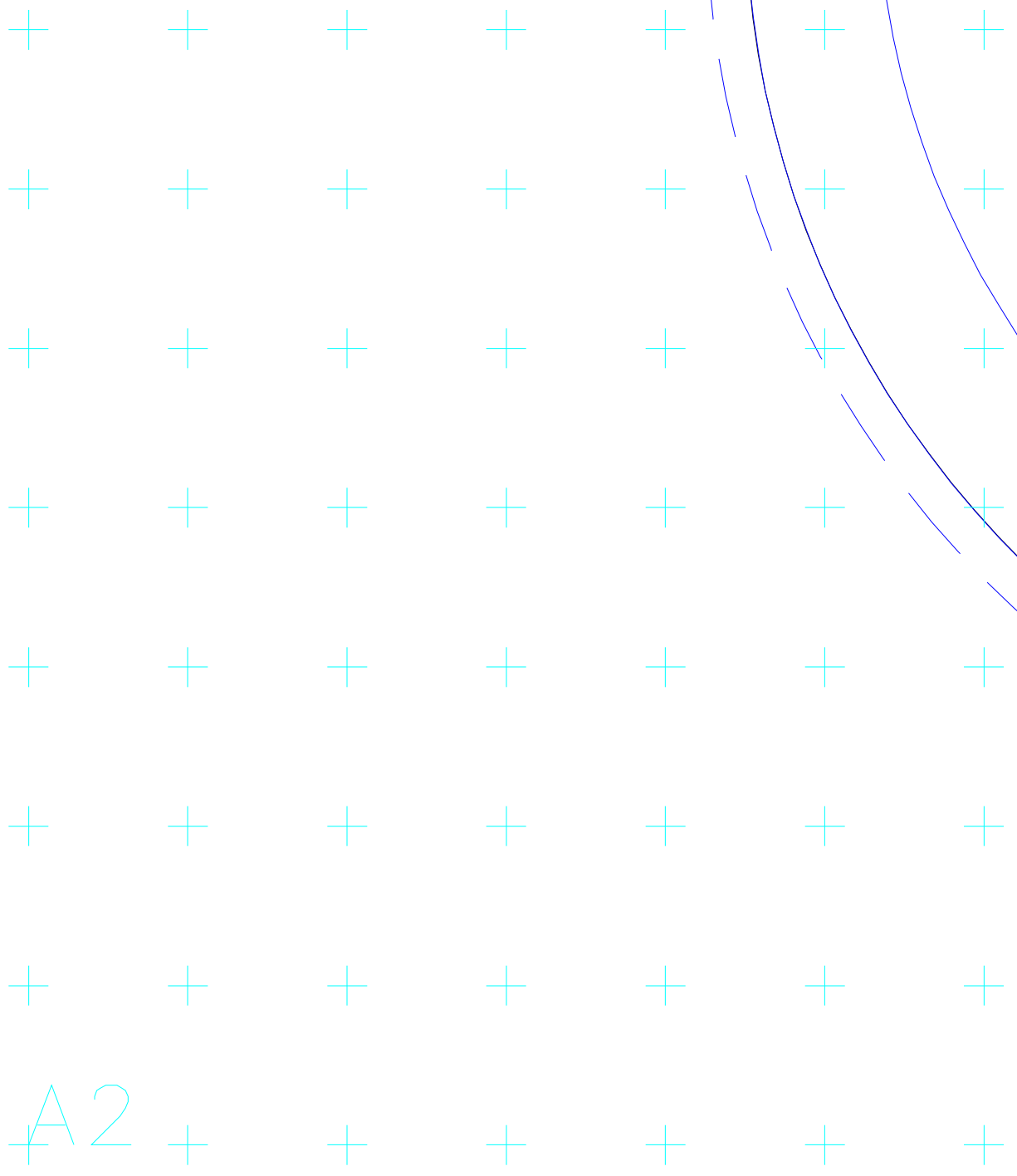

A2

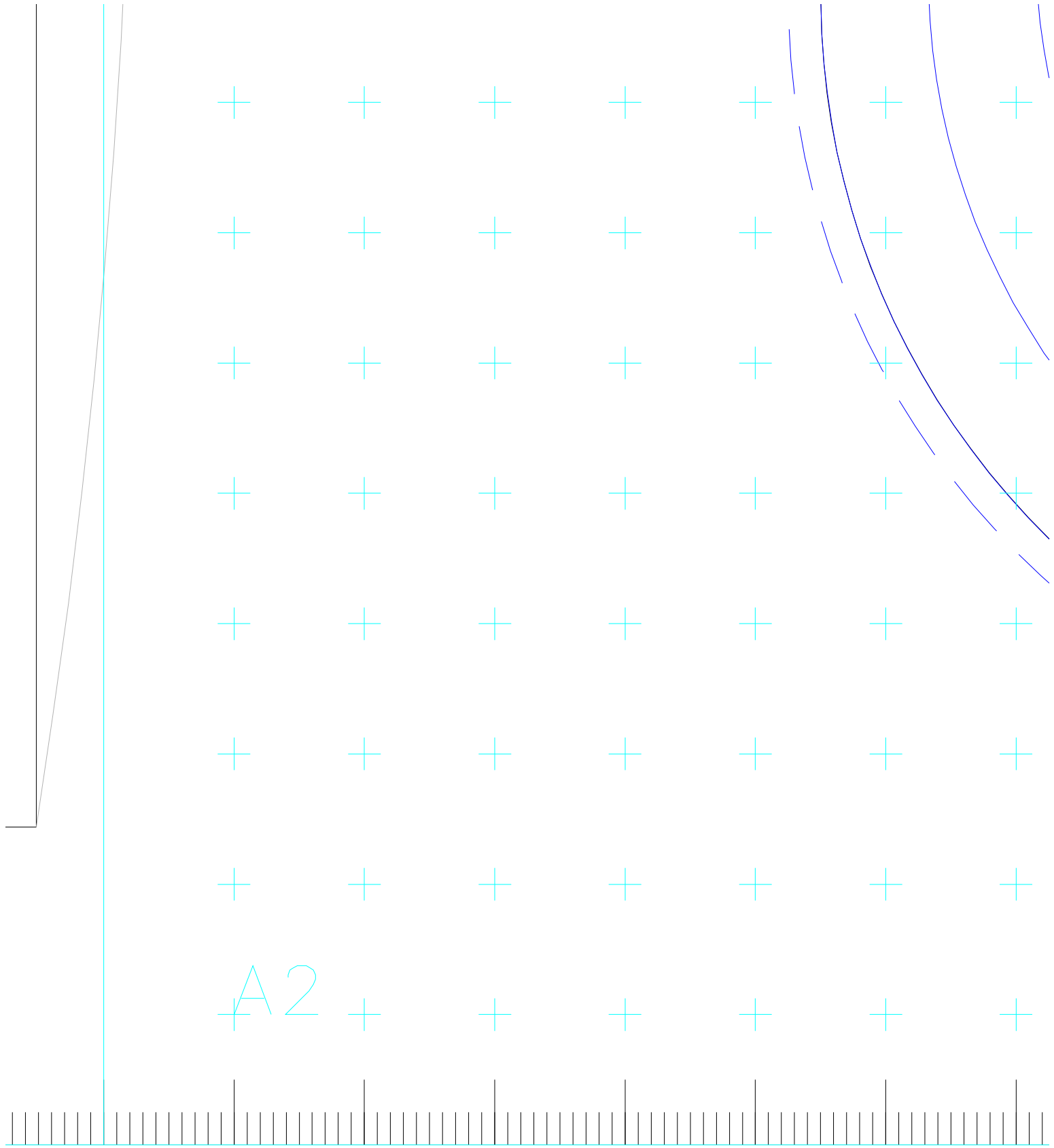

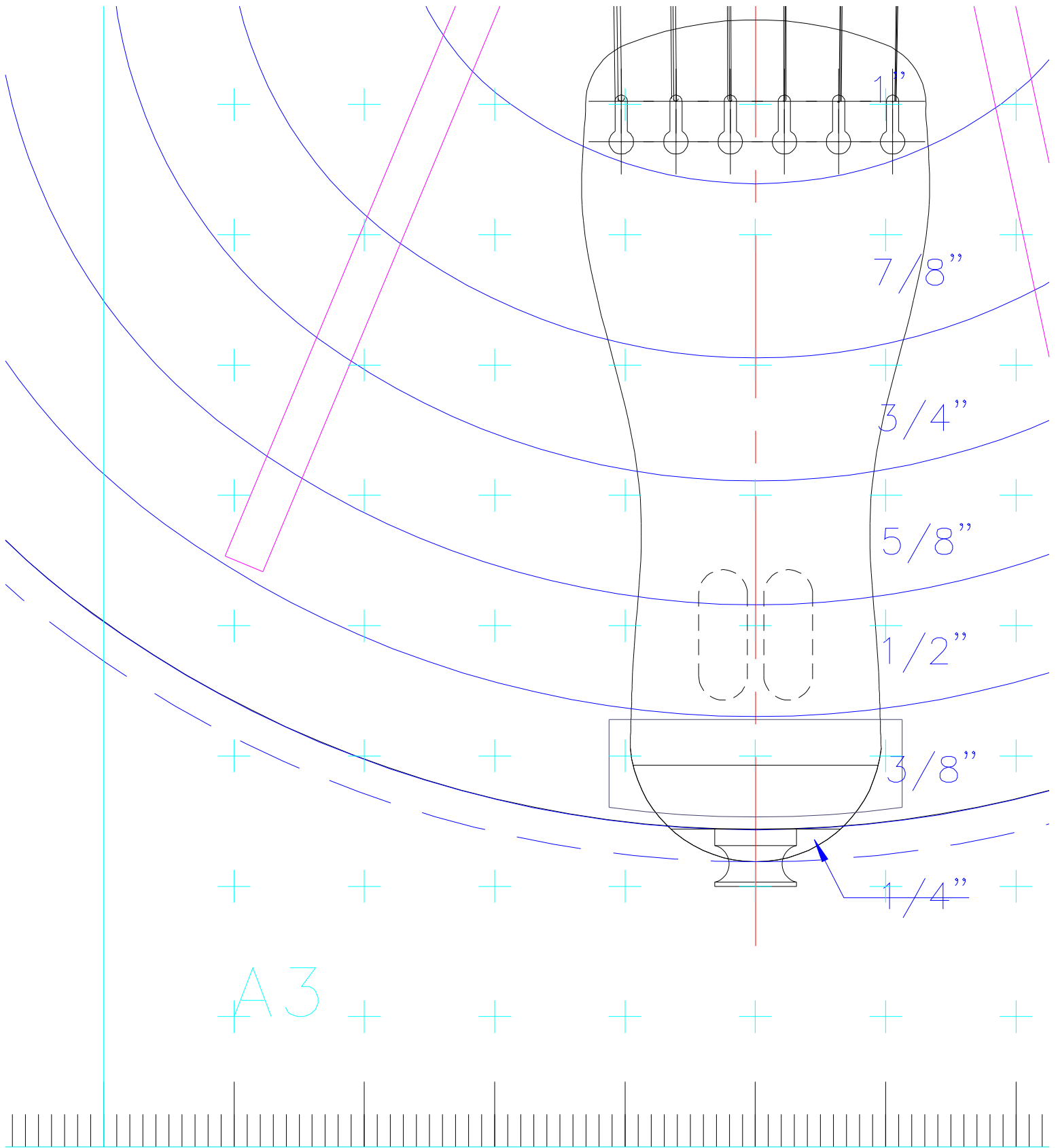

A3

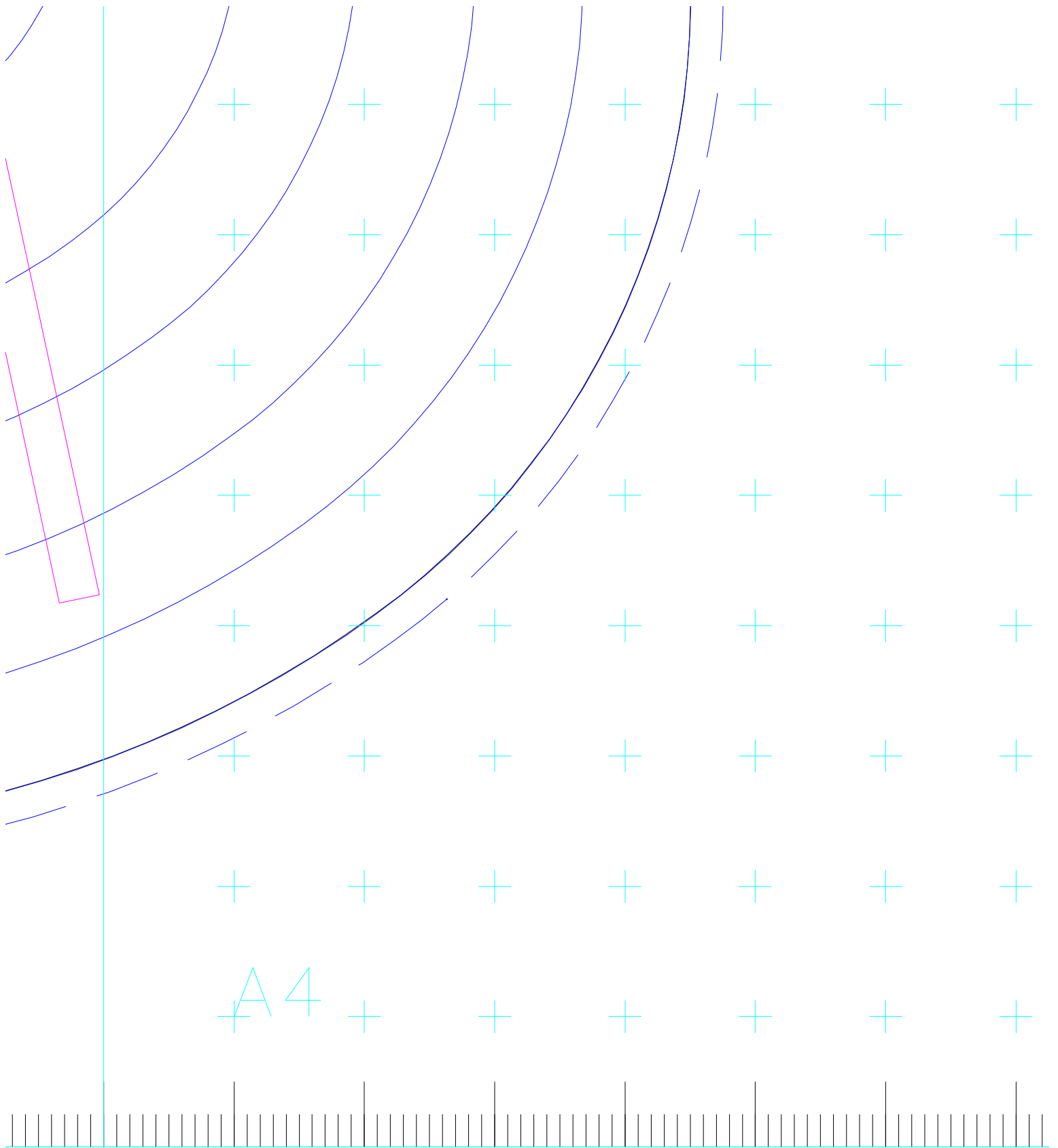

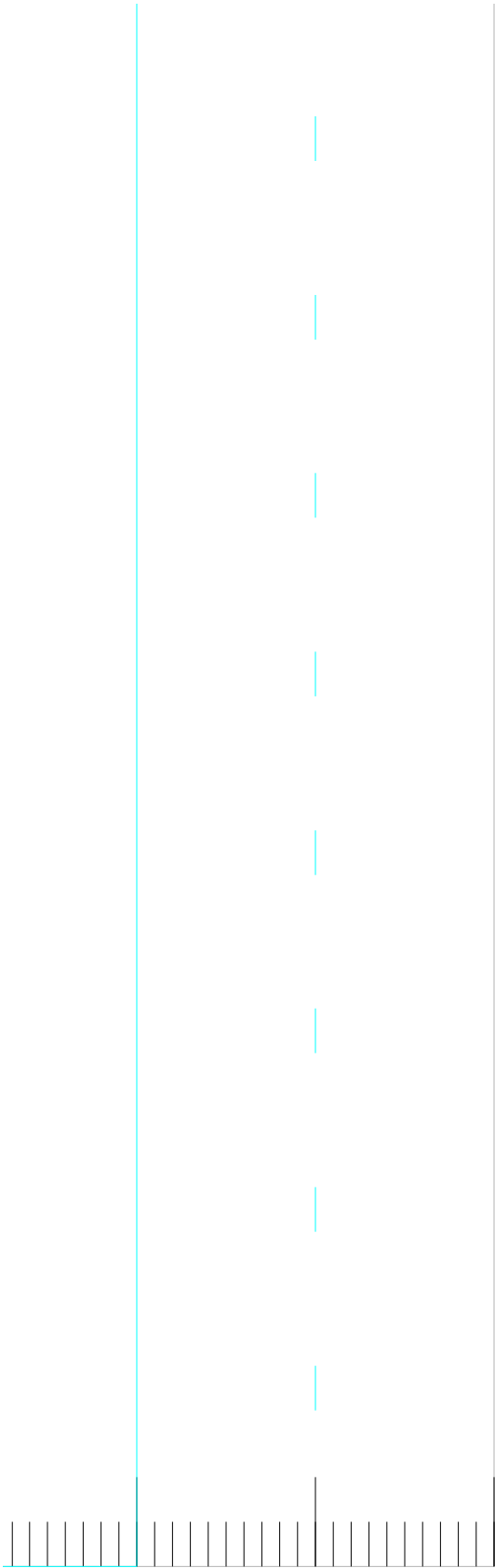

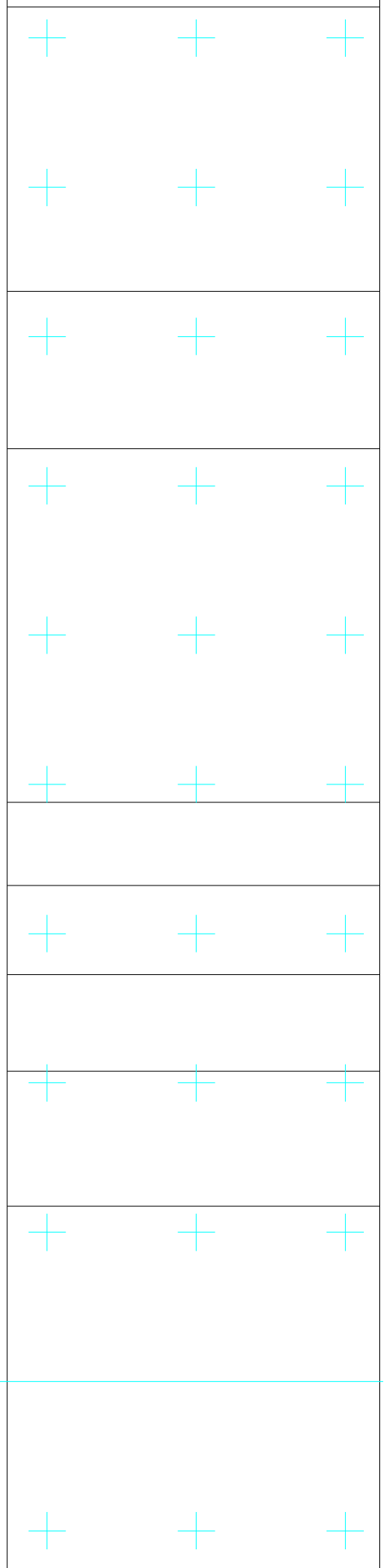
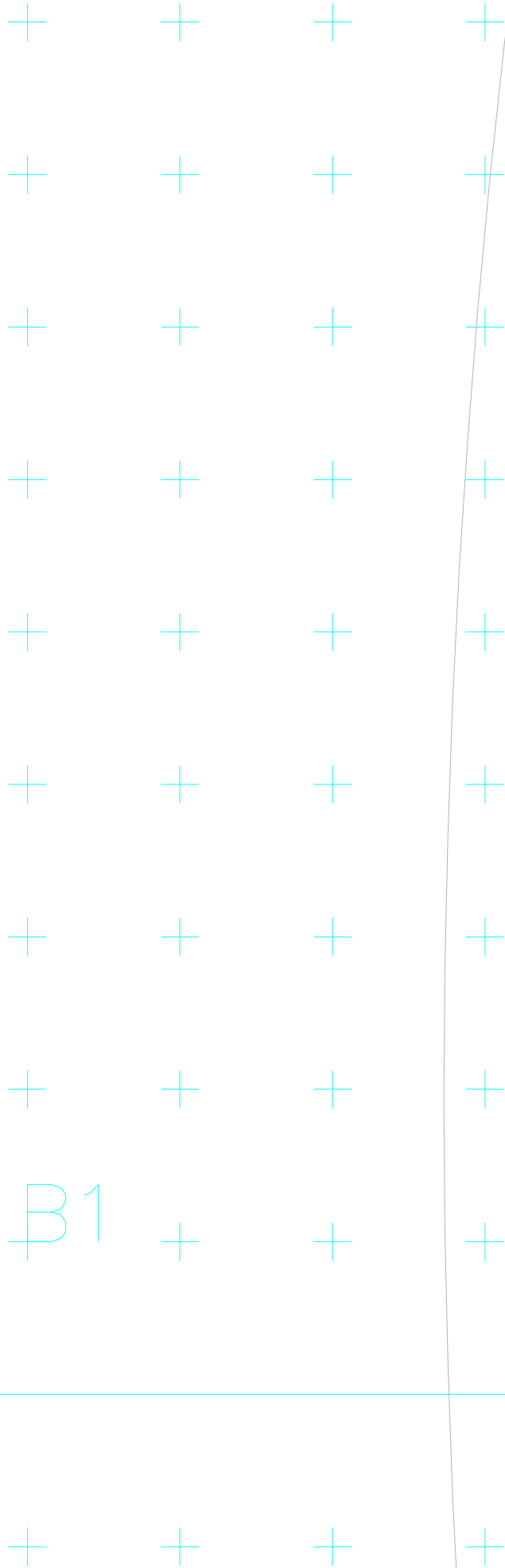



B2

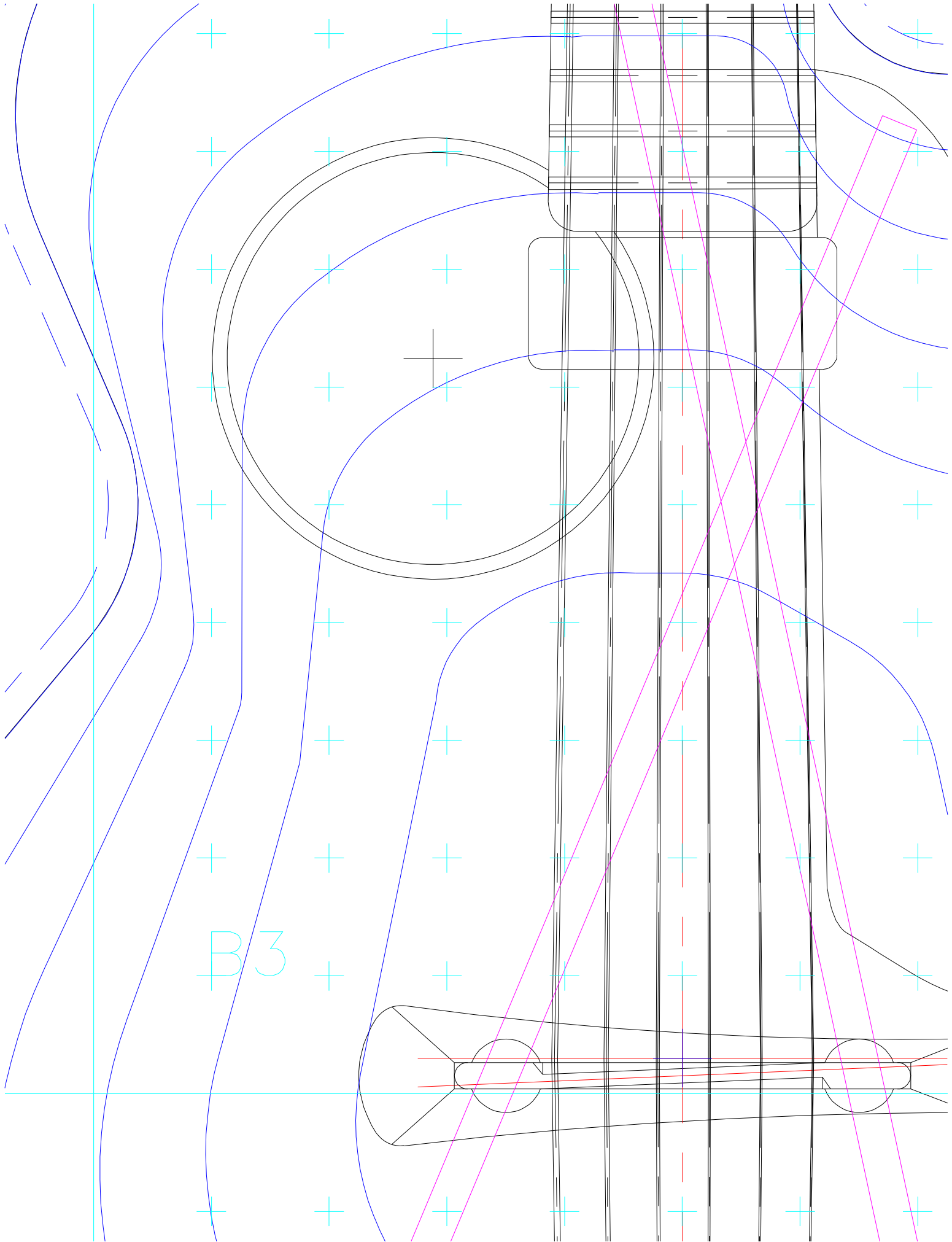

B3

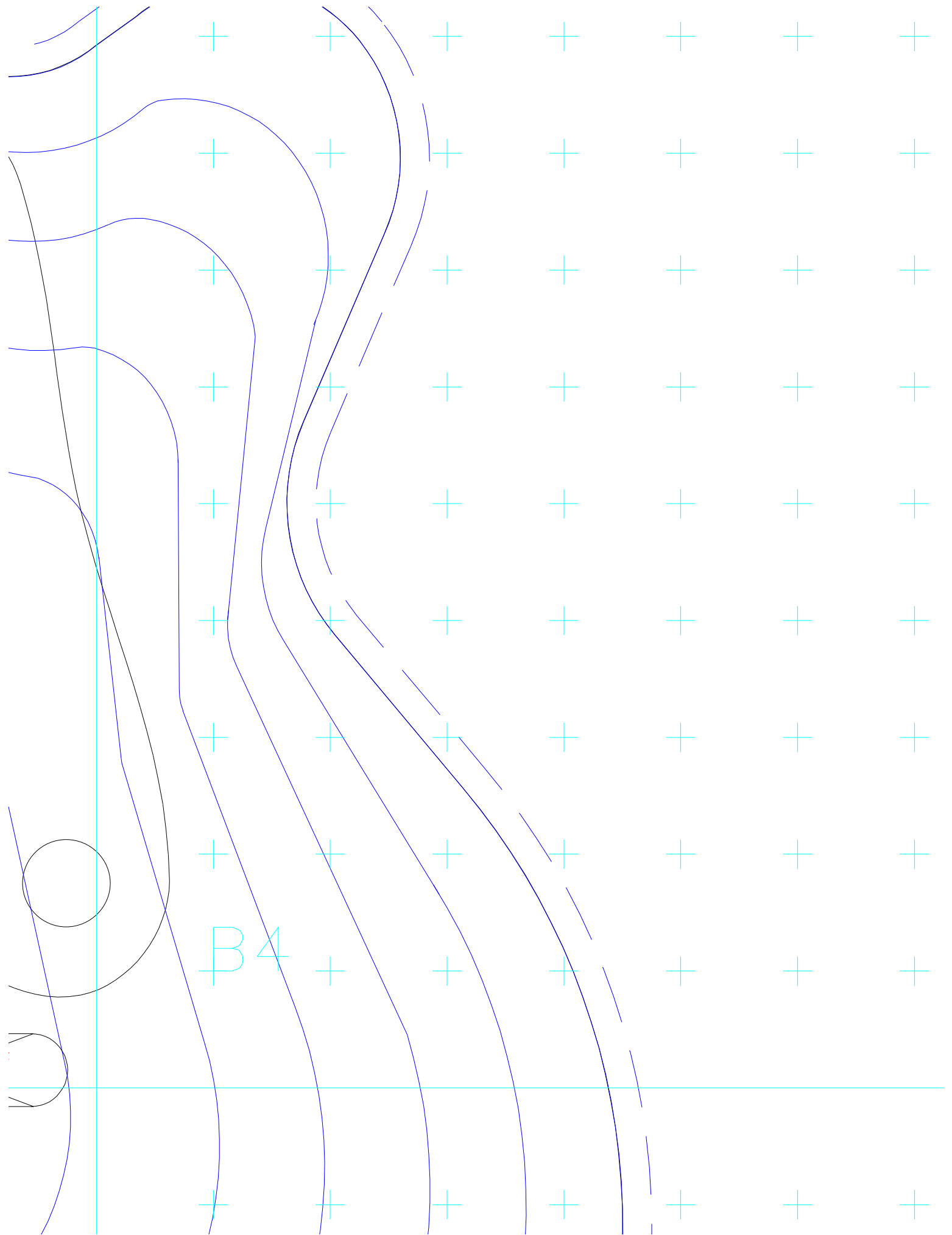

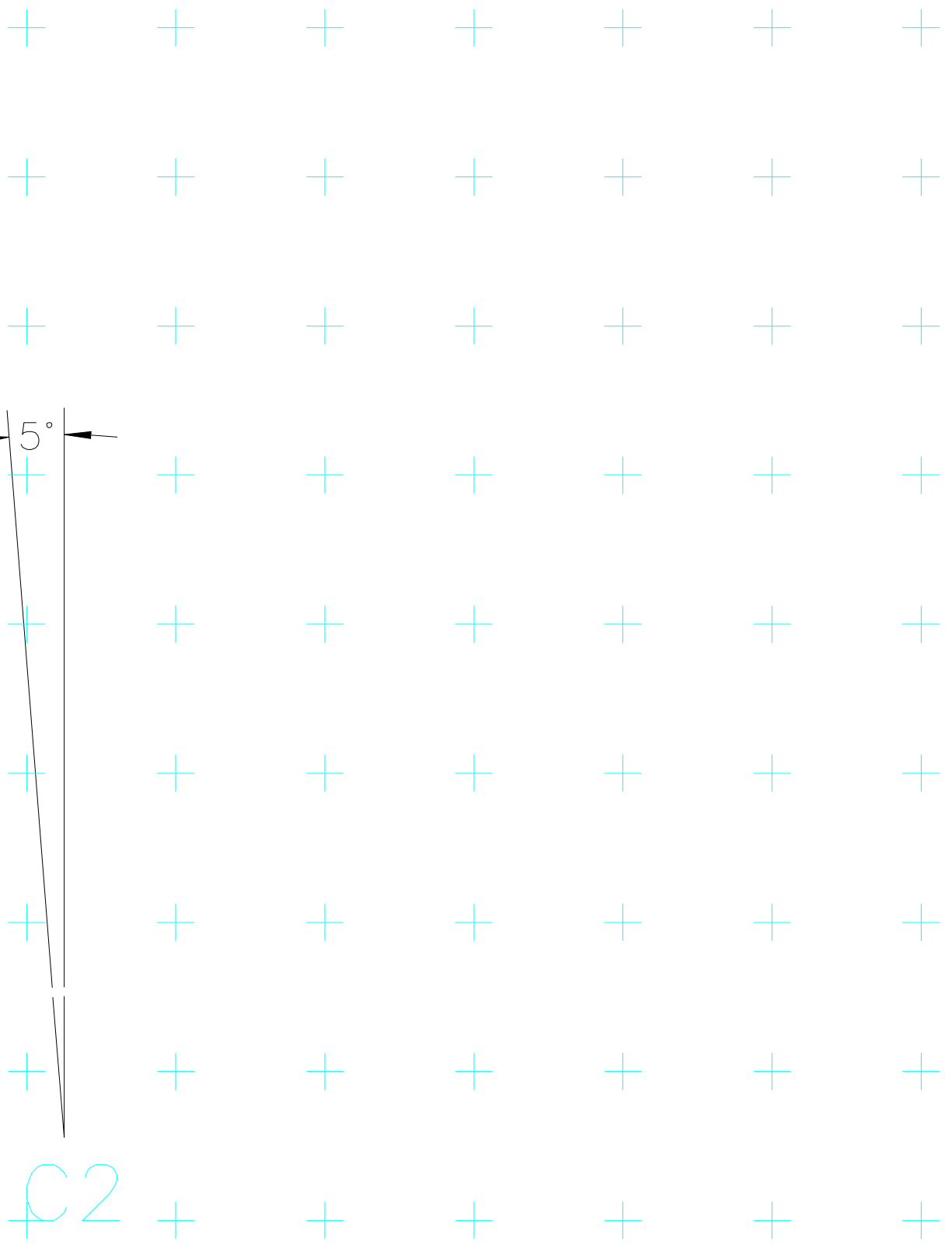
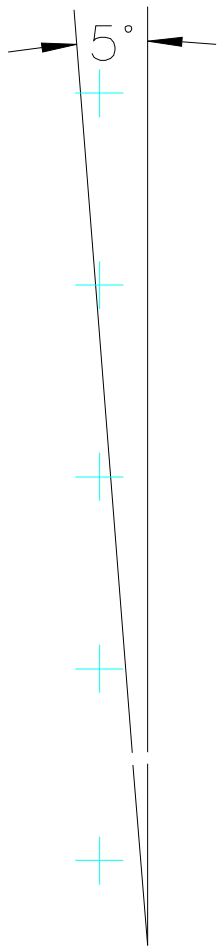
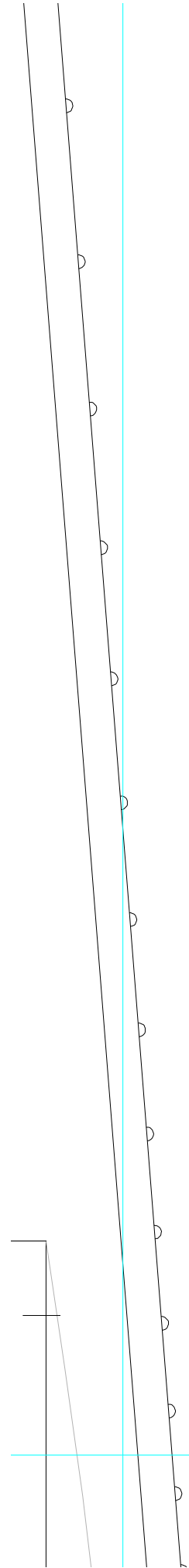

C2

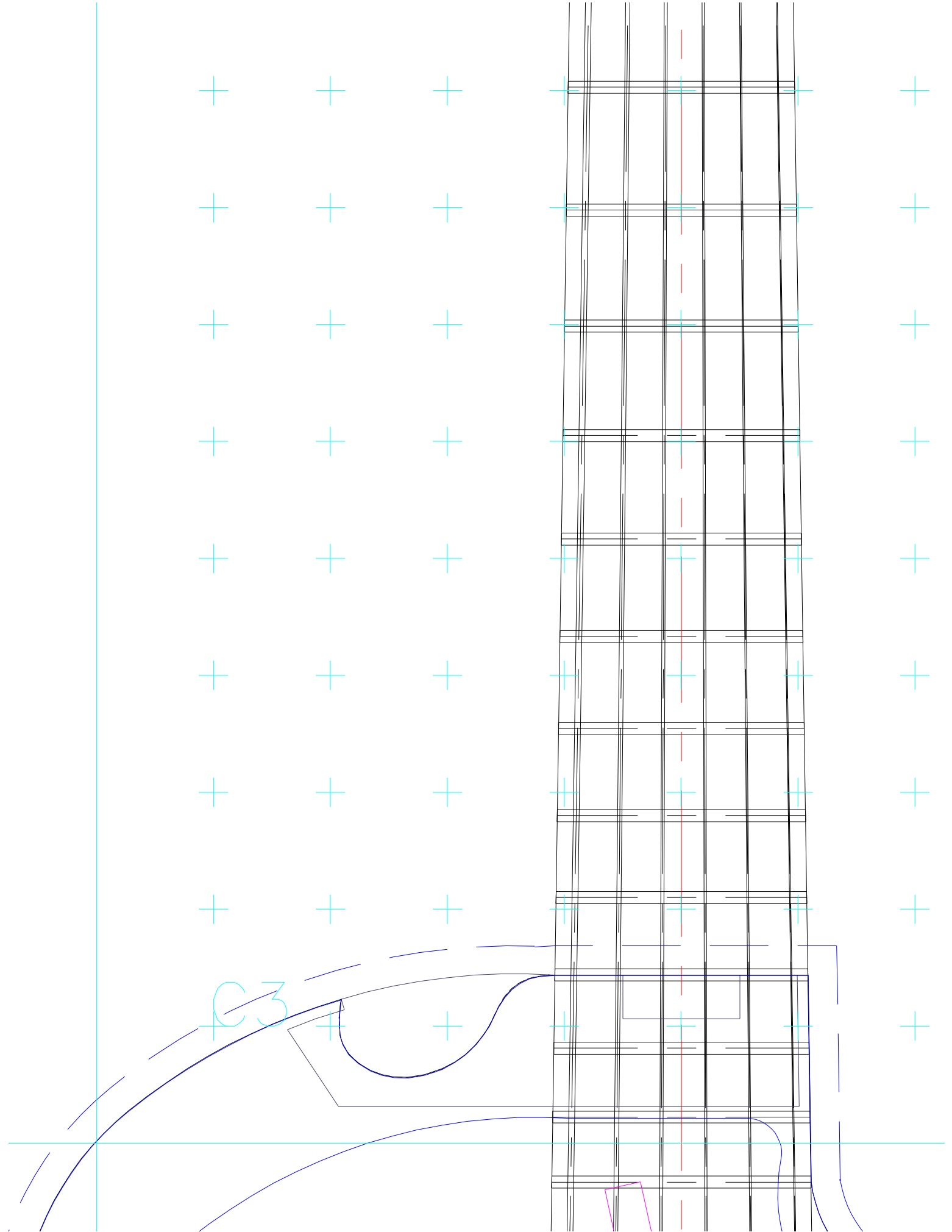

as a cut into the ex
neck block. If the n
is not required a str
width neck block can

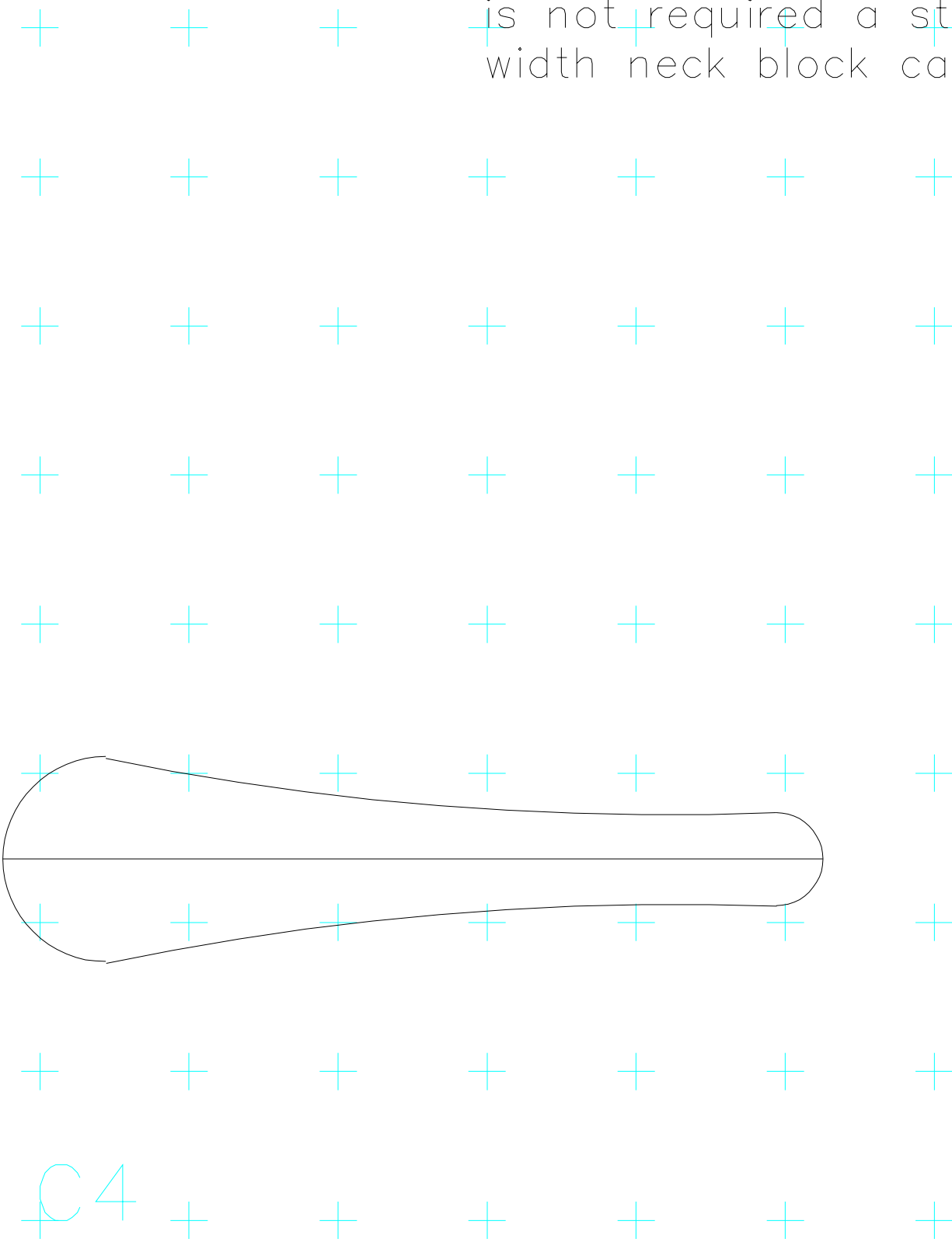

C4

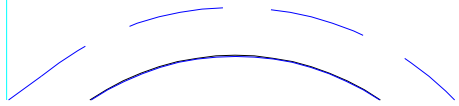

...
mini cutaway
standard
be used.



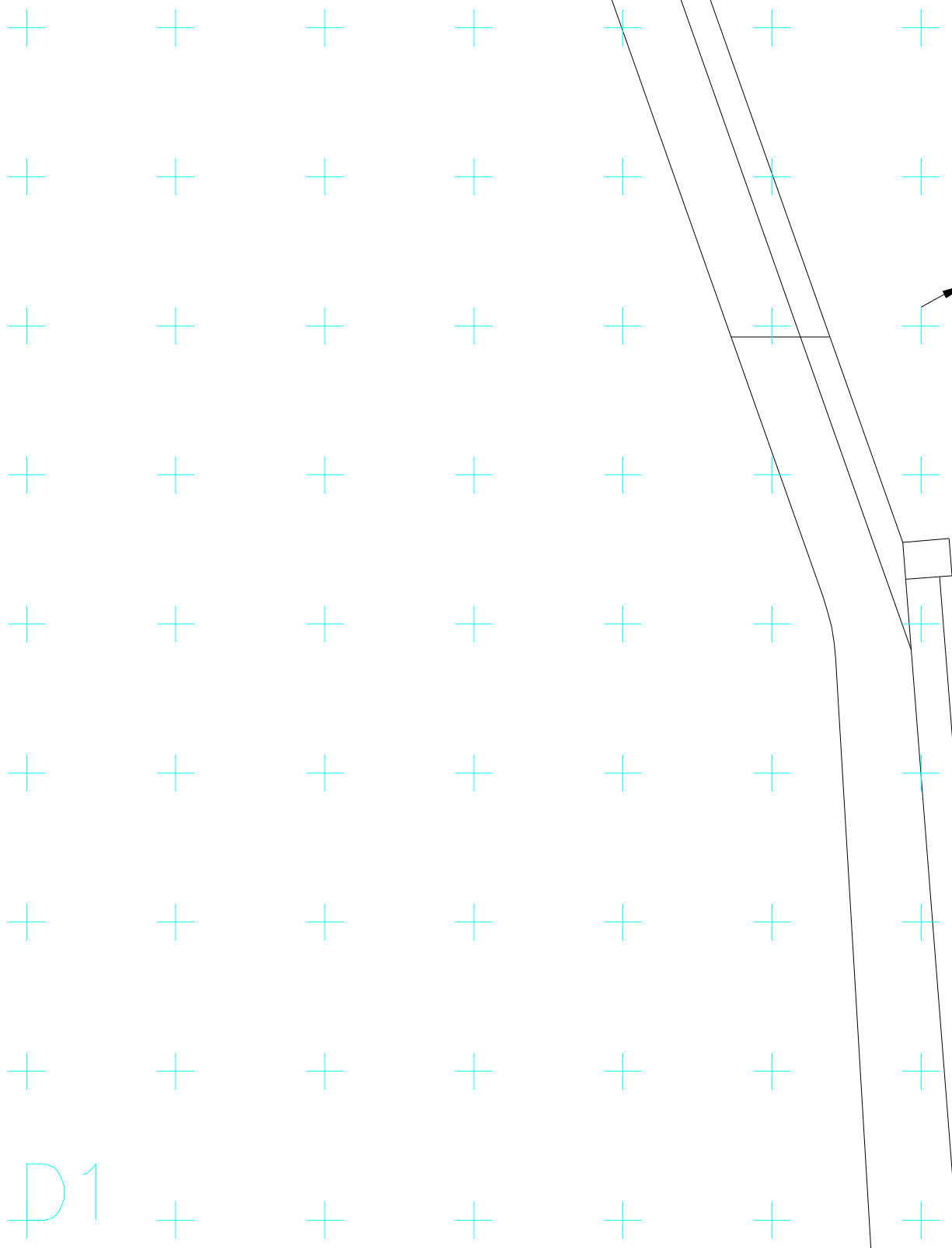

D1

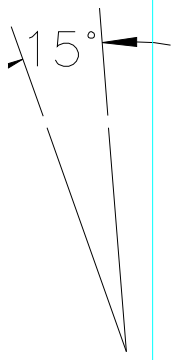
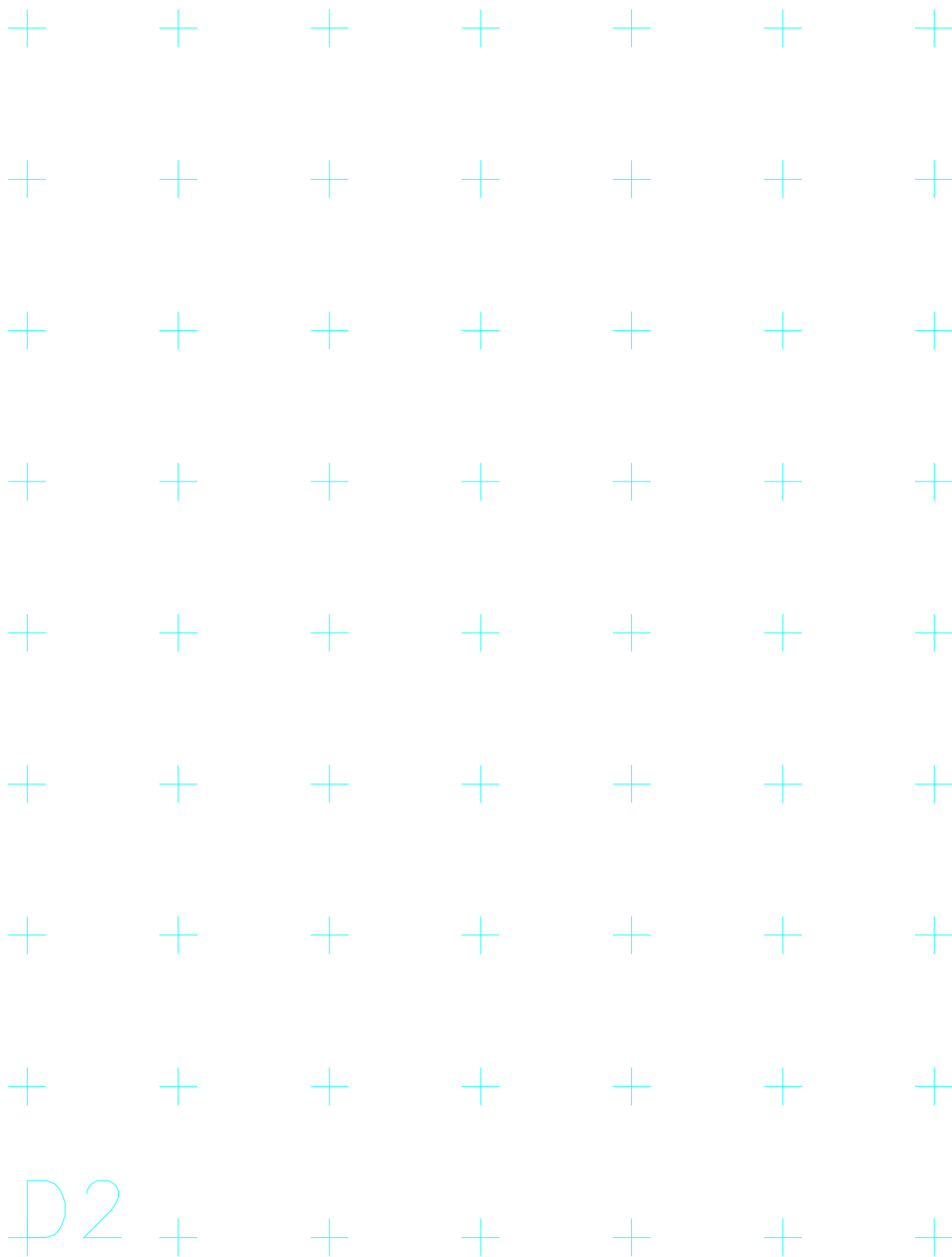

D2

D3

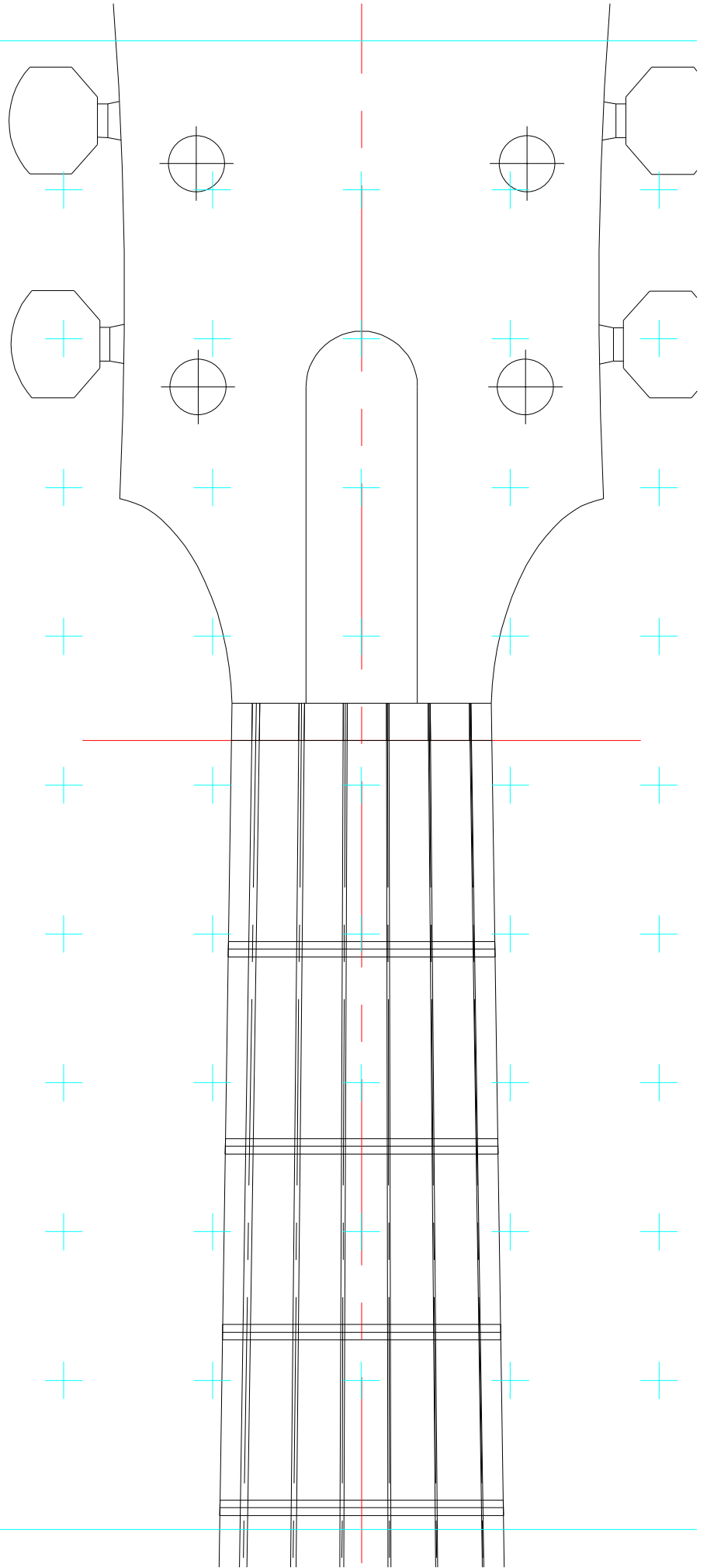

Print Grid
Dimensions
Reference Line:
Hardware

Scale: 1:1

Copyright (c) 2003 R.I
This plan is made available for non-comme
redistributed. If this plan is obtained from a
LiutaioMottola.com it has been copied in vi

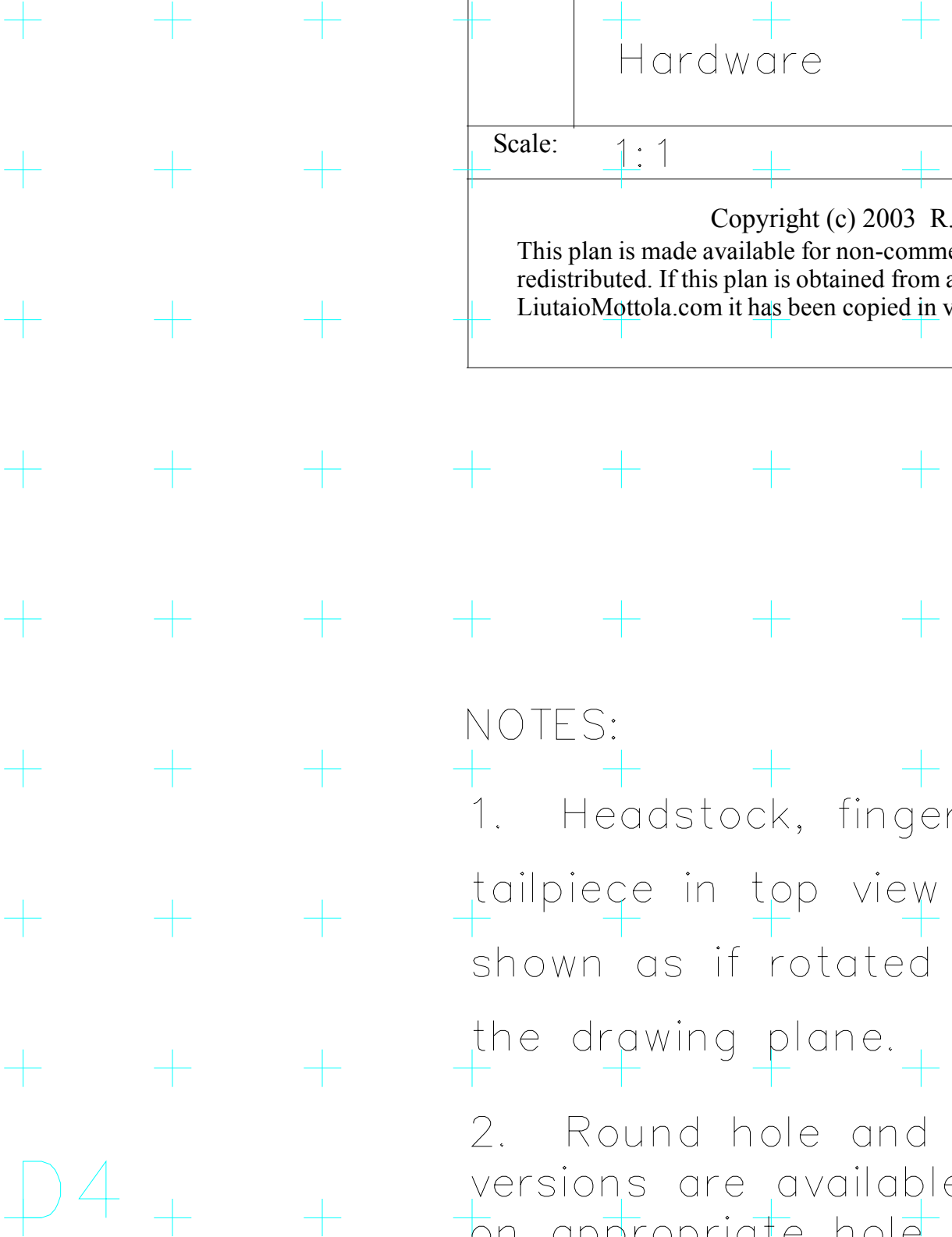

NOTES:

1. Headstock, finger tailpiece in top view shown as if rotated the drawing plane.
2. Round hole and versions are available on appropriate hole & bracing layers.
3. Mini cutaway is i
as a cut into the ov

ie

Strings
Titleblock

S

RoundHole

Sheet 1 of 1

M. Mottola

ercial use only and may not be
ny source other than
iolation of copyright.

board, and
drawing are
parallel to

F hole
Turn
and top

mplemented
tended

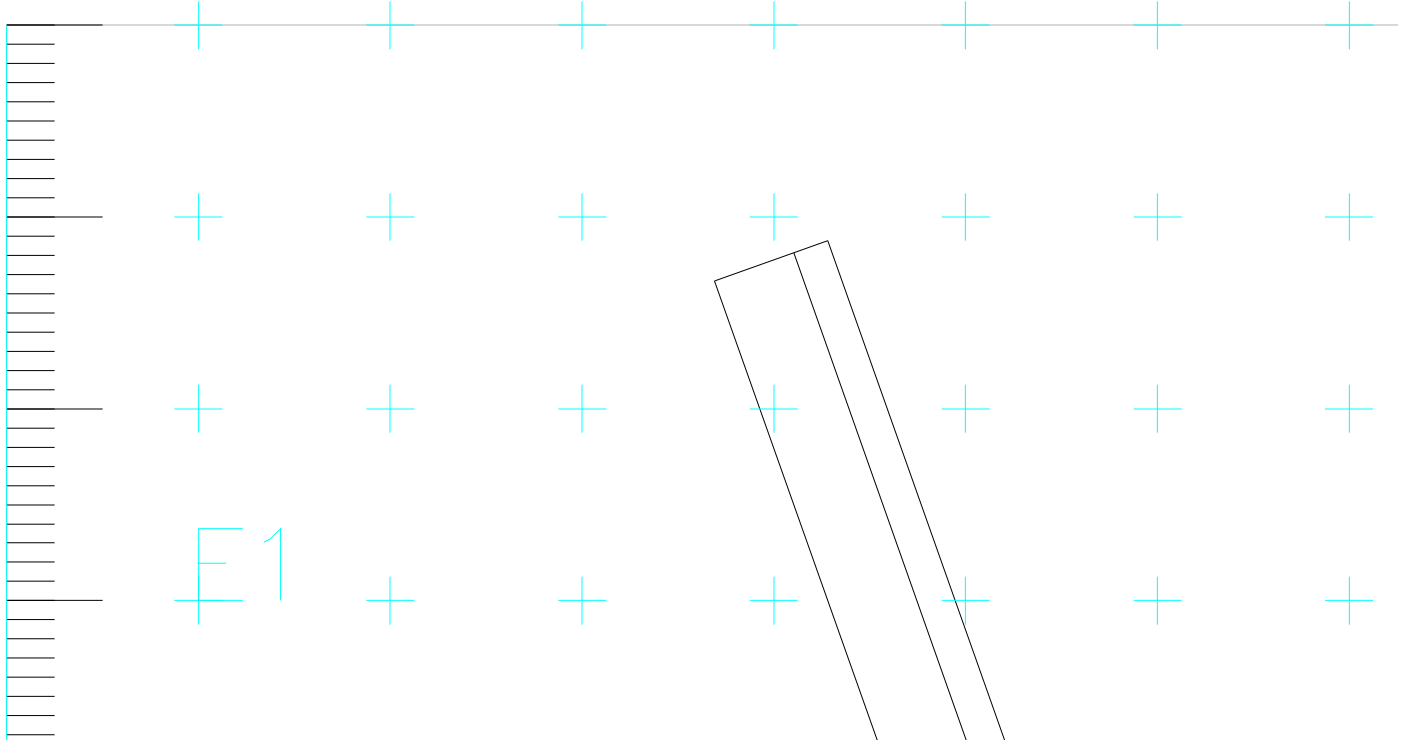

E1



F3

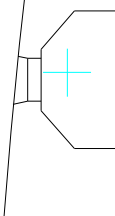
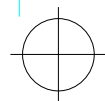
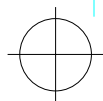
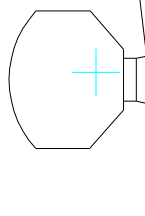

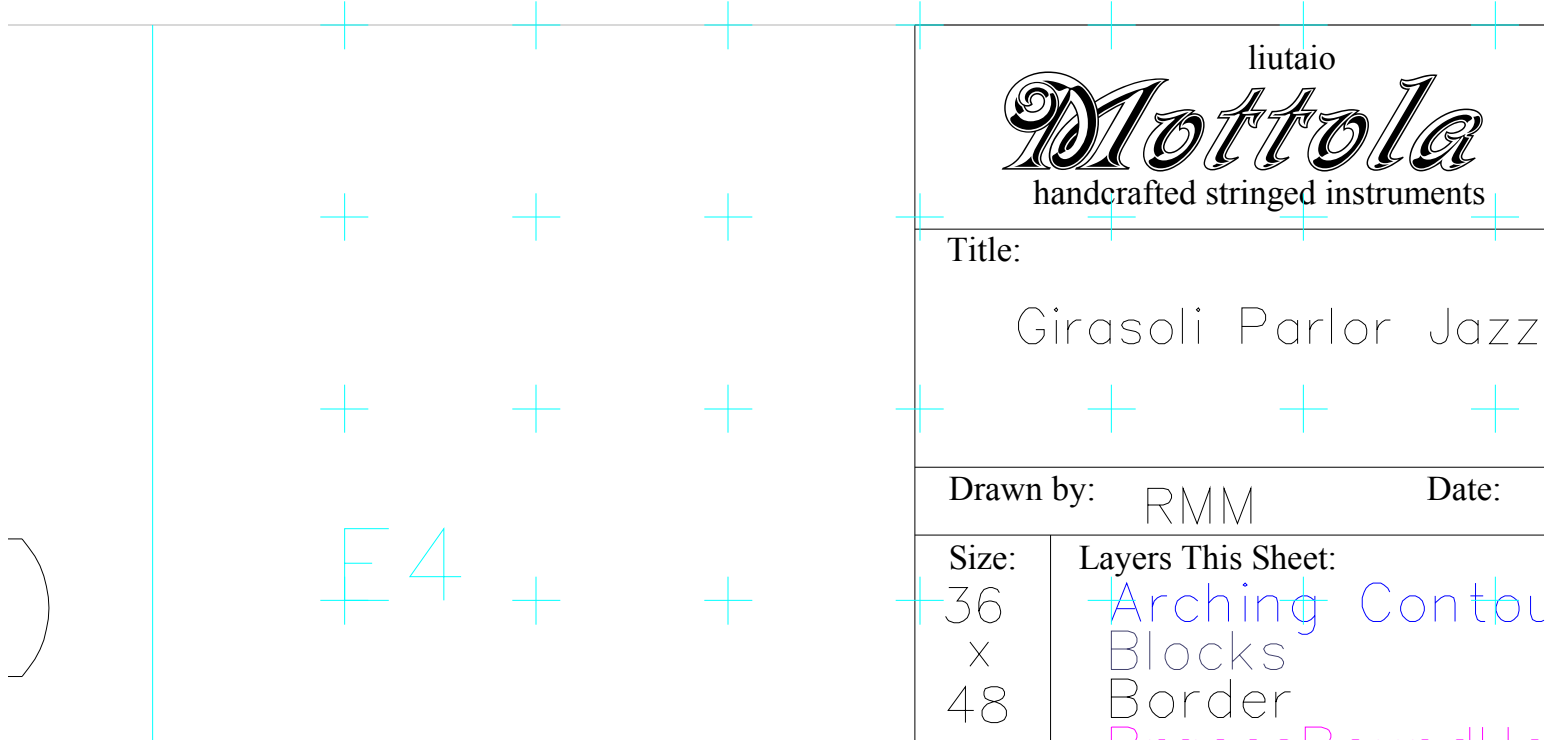

liutaio

Mottola

handcrafted stringed instruments

Title:

Girasoli Parlor Jazz

Drawn by: RMM

Date:

Size:
36
x
48

Layers This Sheet:
Arching Contour
Blocks
Border
Drum Round 1a

E4

)

<http://www.LiutaioMottola.com>

Guitar

7/15/03

ur

Neck |
Body
Notes

10