

Title: Girasoli Parlor Jazz Guitar		
Drawn by: RMM	Date: 7/15/03	
Size: 36 x 48	Layers This Sheet: Arching Contour Blocks Border	Neck Body Notes
	Print Grid Dimensions Reference Lines	Strings Titleblock FHole
	Hardware Braces FHole	
Scale: 1:1	Sheet 1 of 1	

Copyright (c) 2003 R.M. Mottola
This plan is made available for non-commercial use only and may not be redistributed. If this plan is obtained from any source other than LiviniaMottola.com it has been copied in violation of copyright.

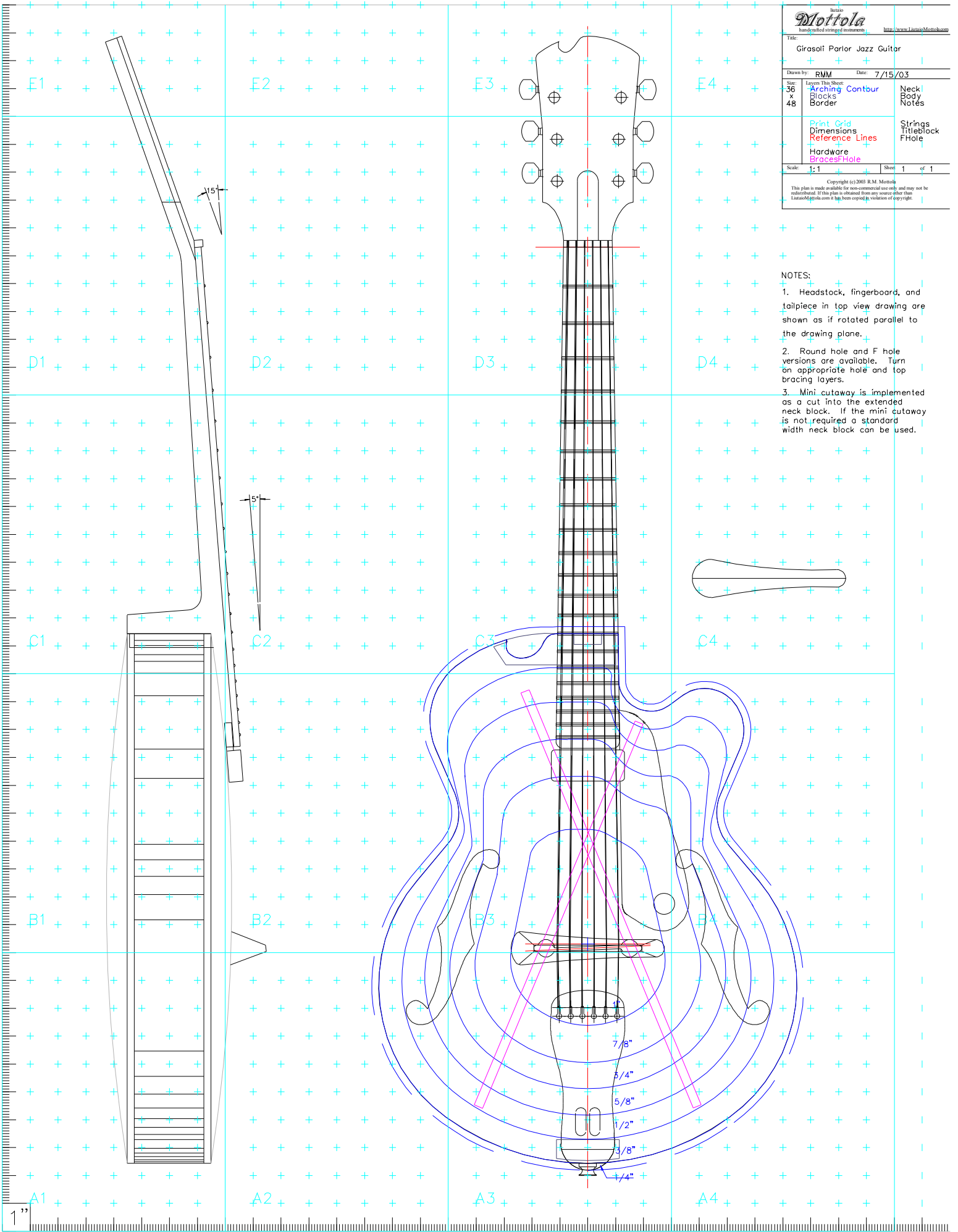

- NOTES:
1. Headstock, fingerboard, and tailpiece in top view drawing are shown as if rotated parallel to the drawing plane.
 2. Round hole and F hole versions are available. Turn on appropriate hole and top bracing layers.
 3. Mini cutaway is implemented as a cut into the extended neck block. If the mini cutaway is not required a standard width neck block can be used.

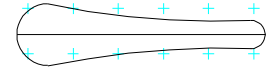

1"

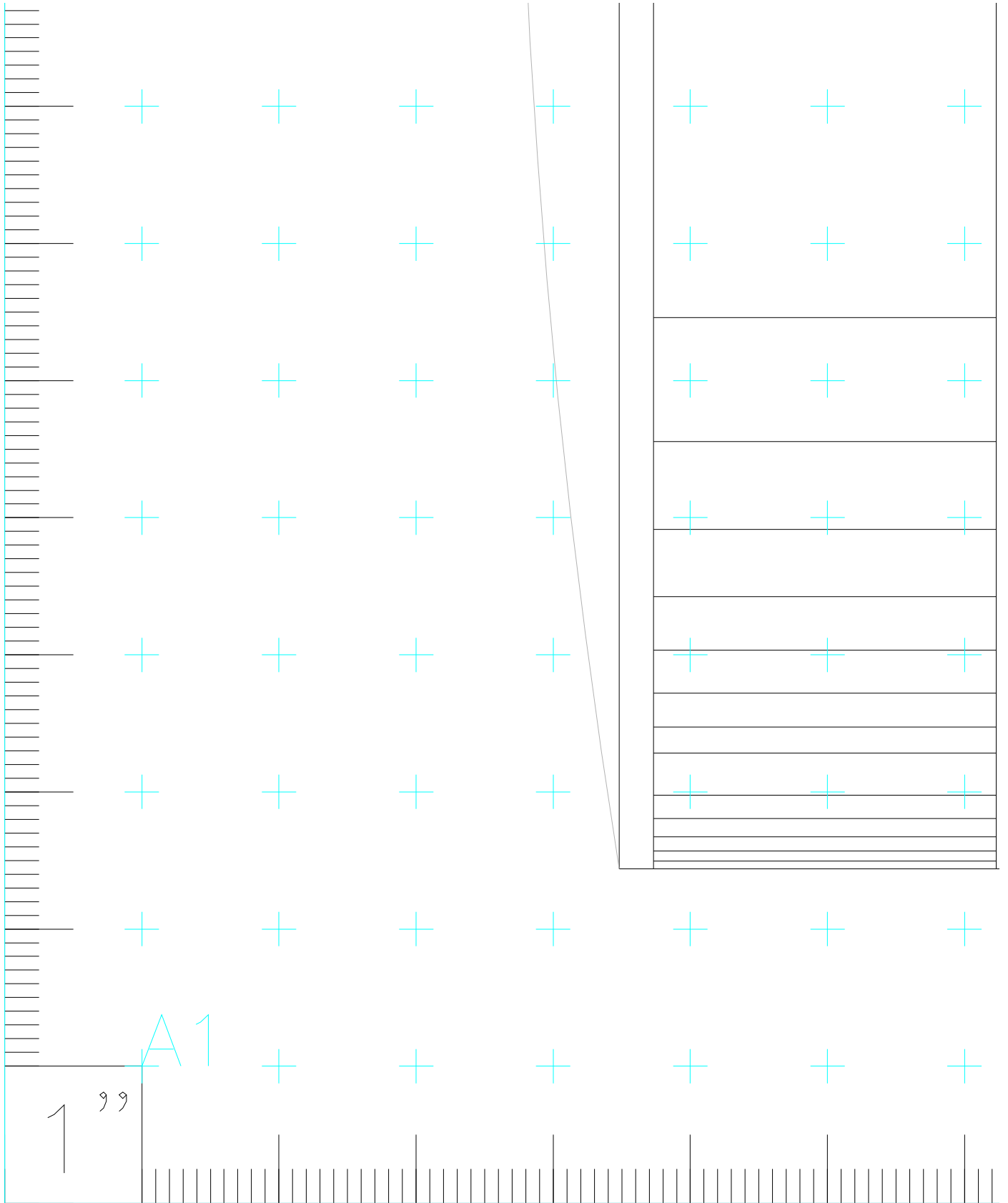

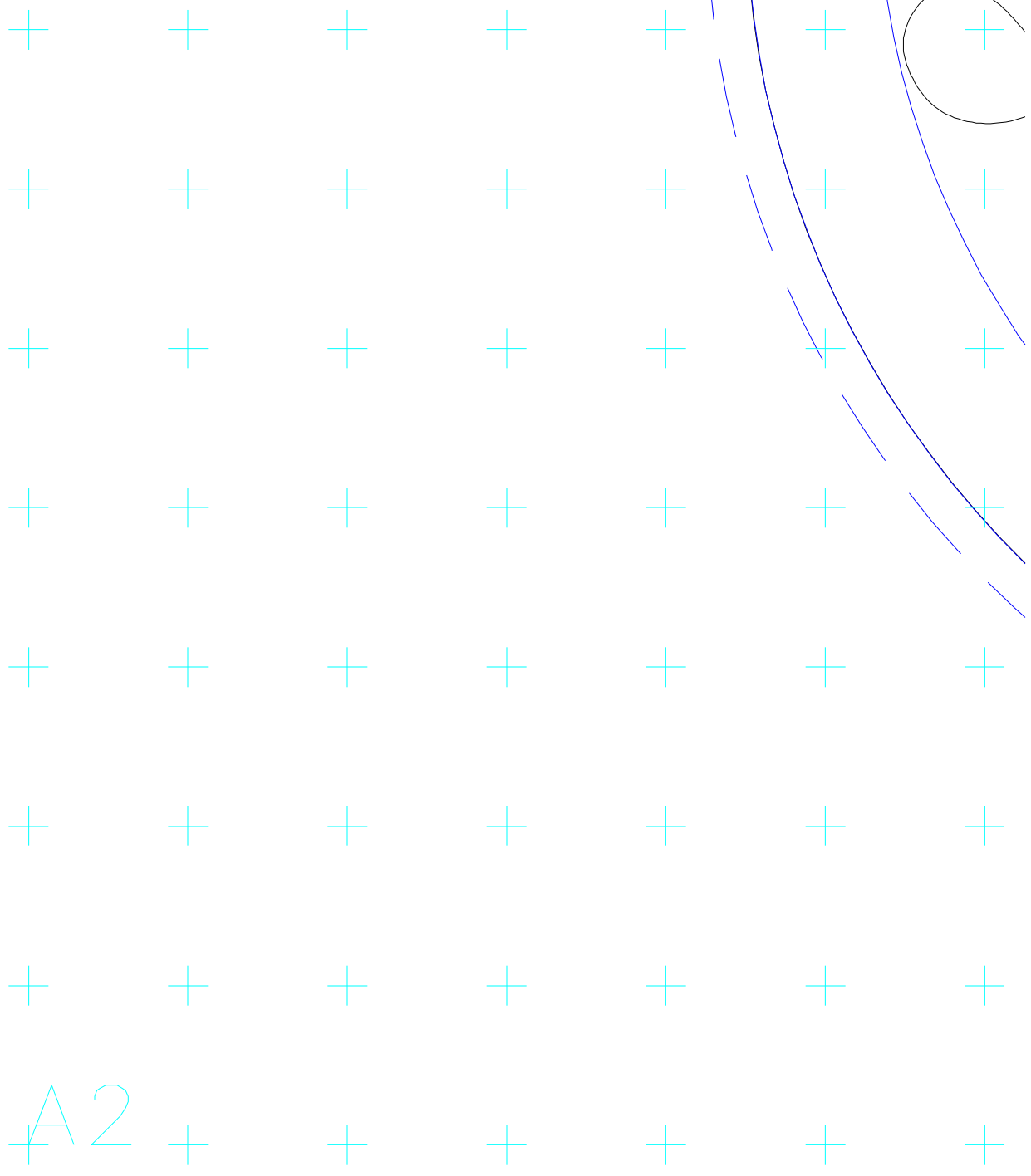

A2

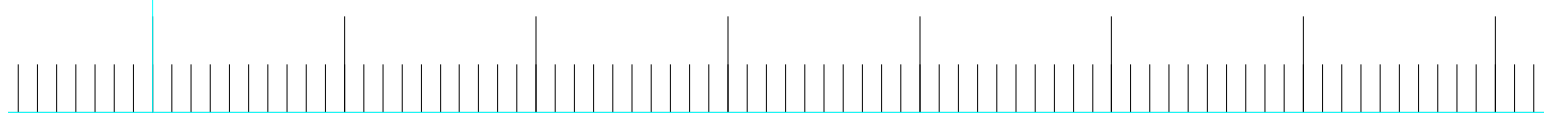

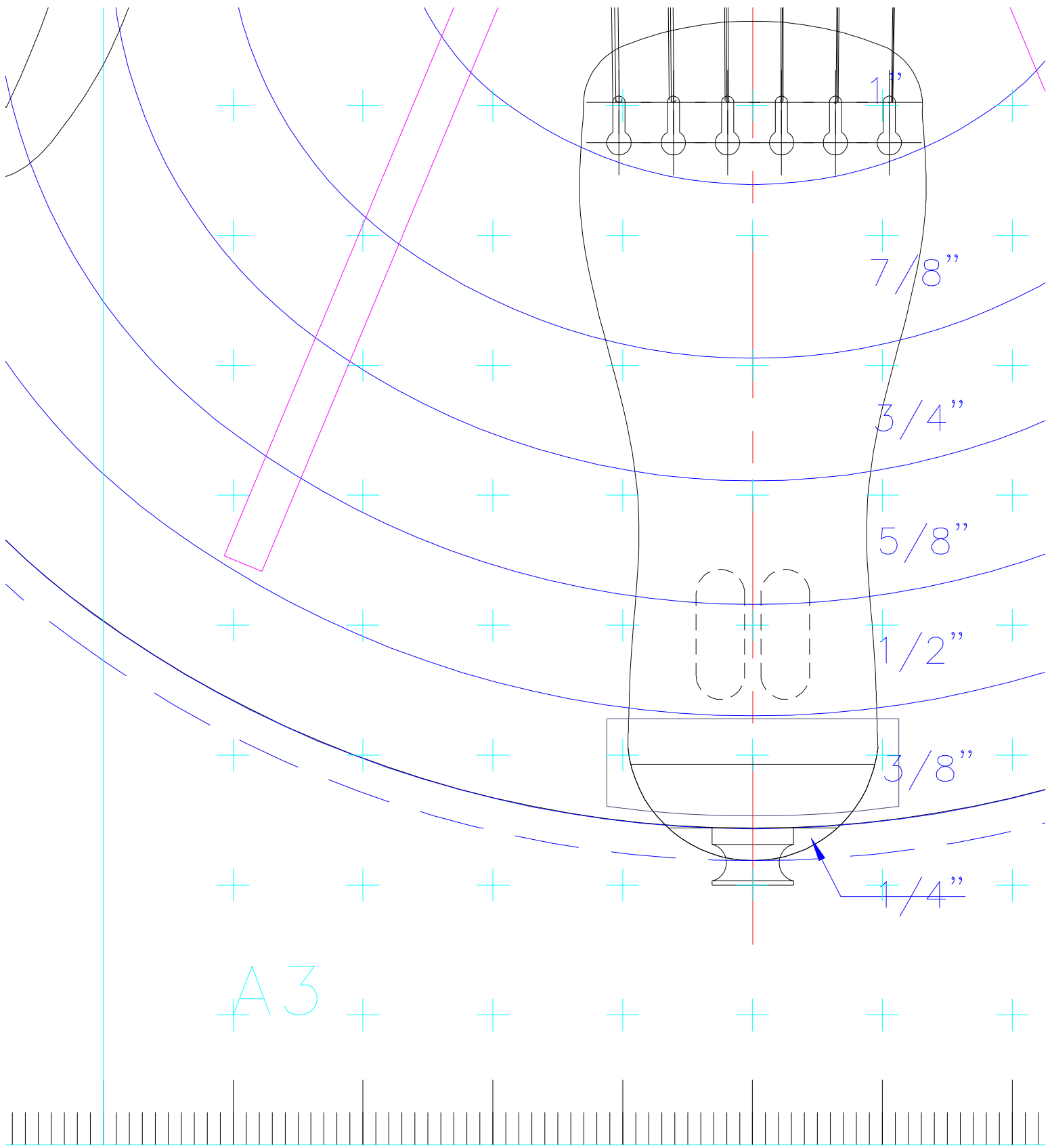

A3

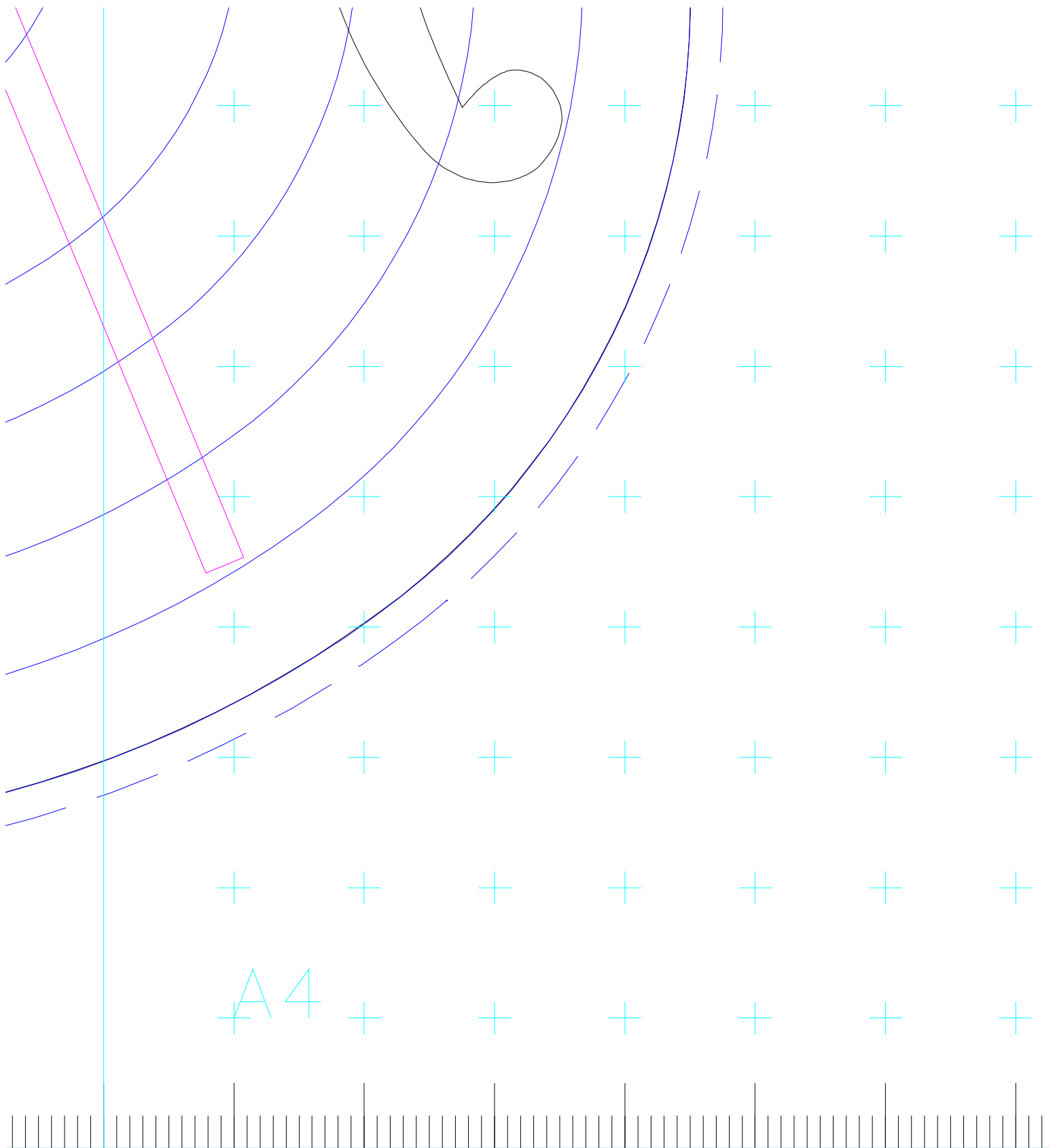

A 4

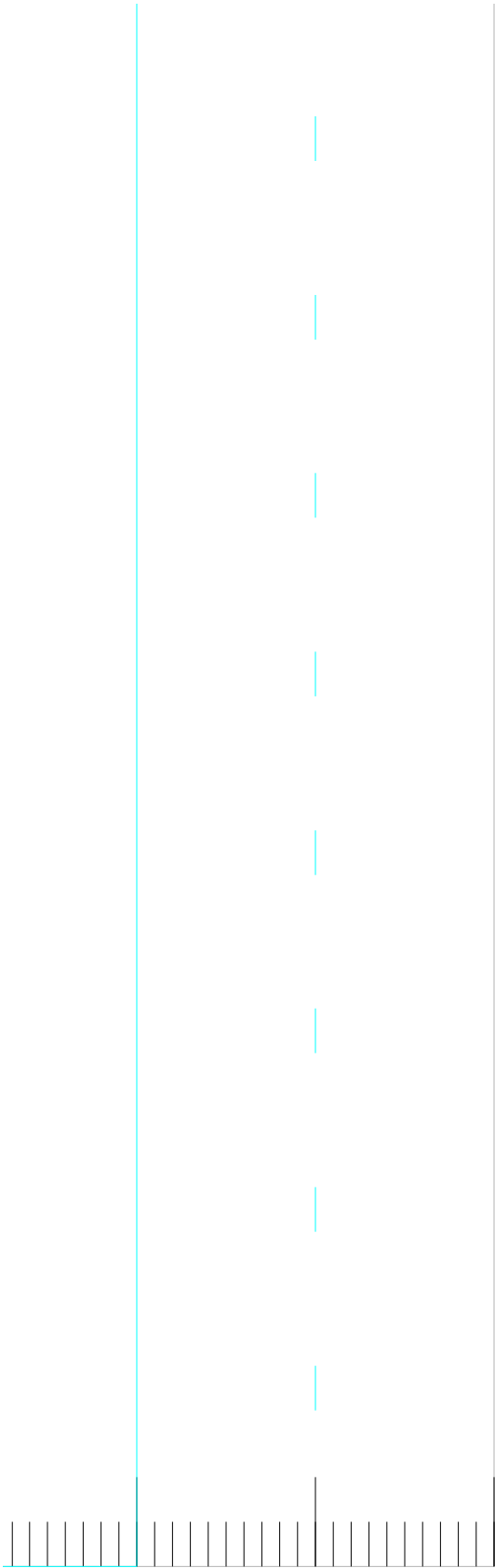

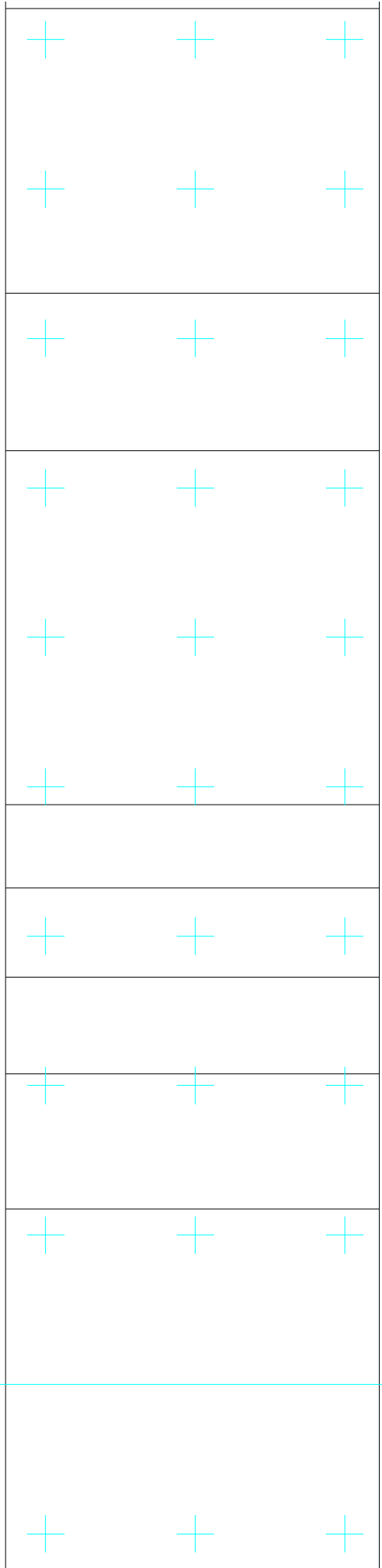

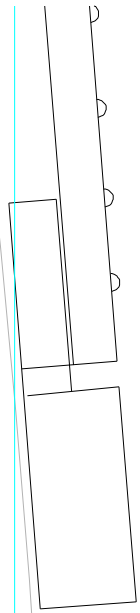

B2

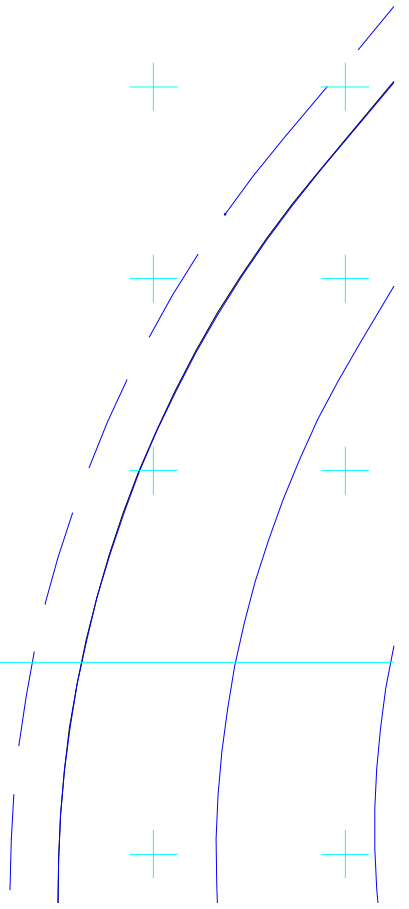

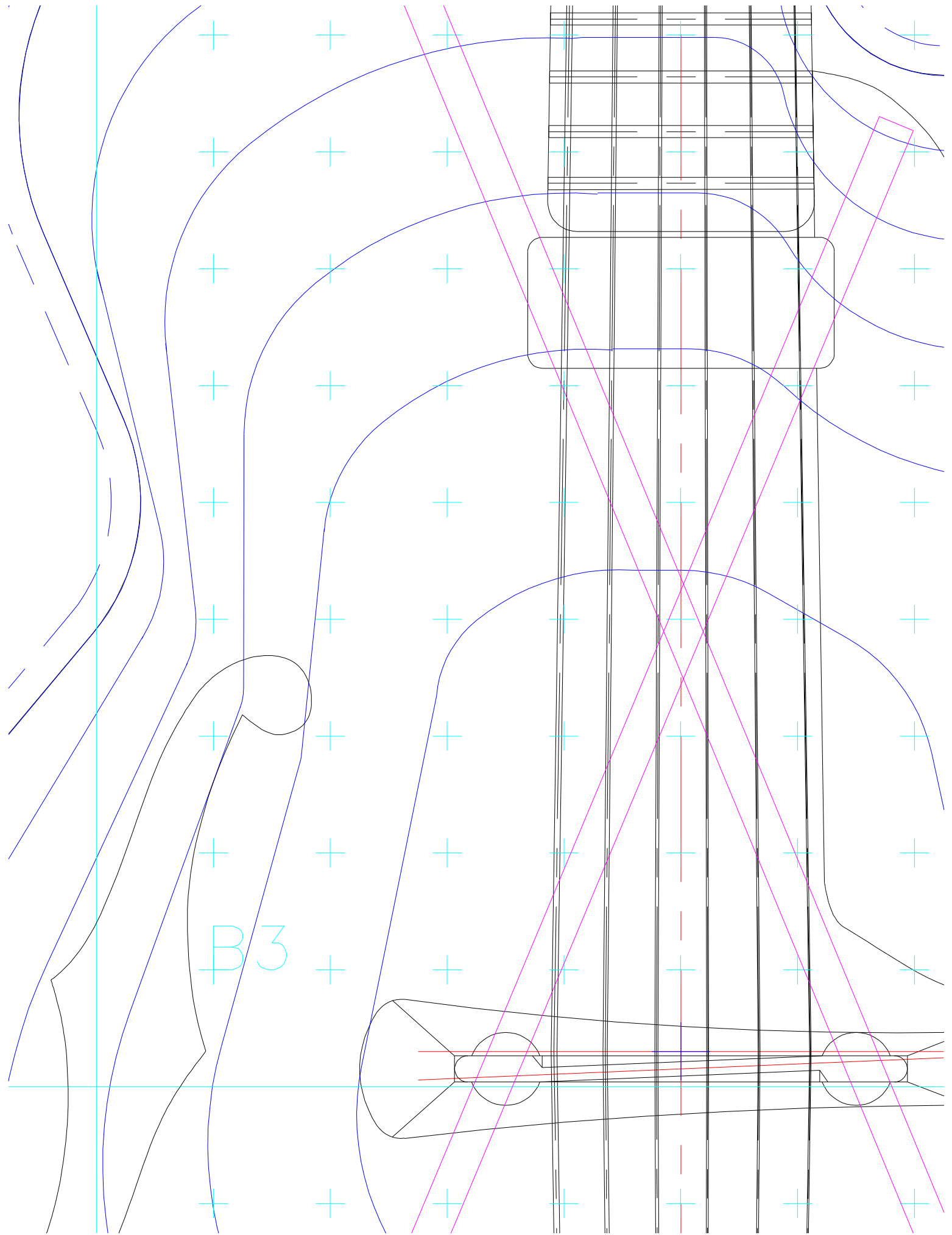

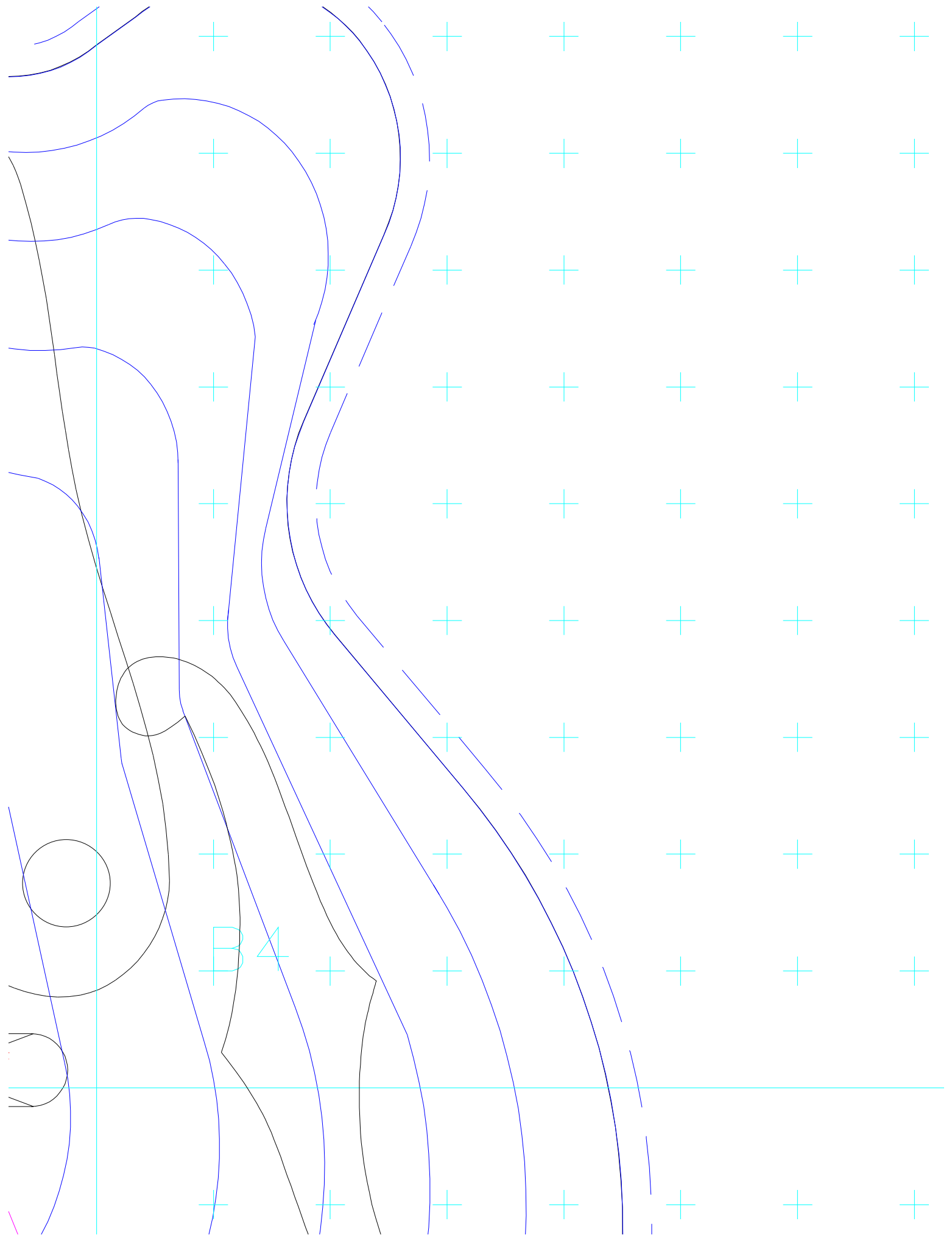

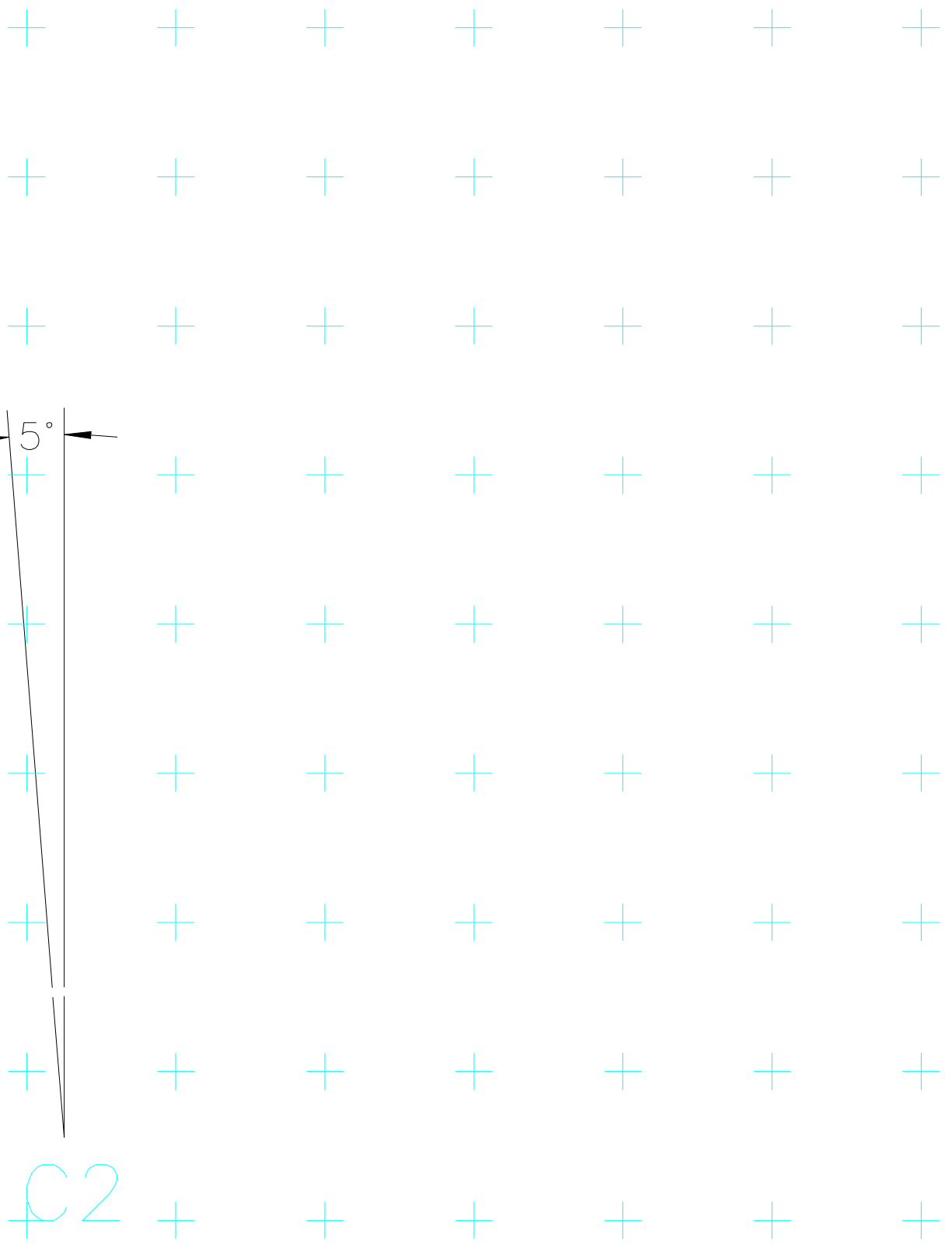
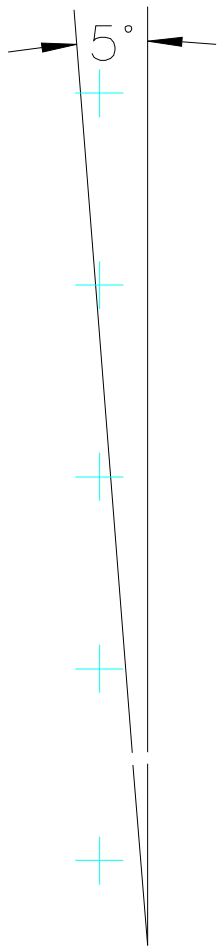
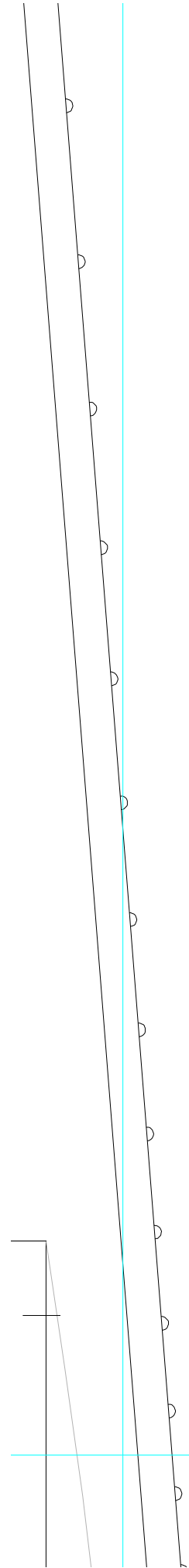

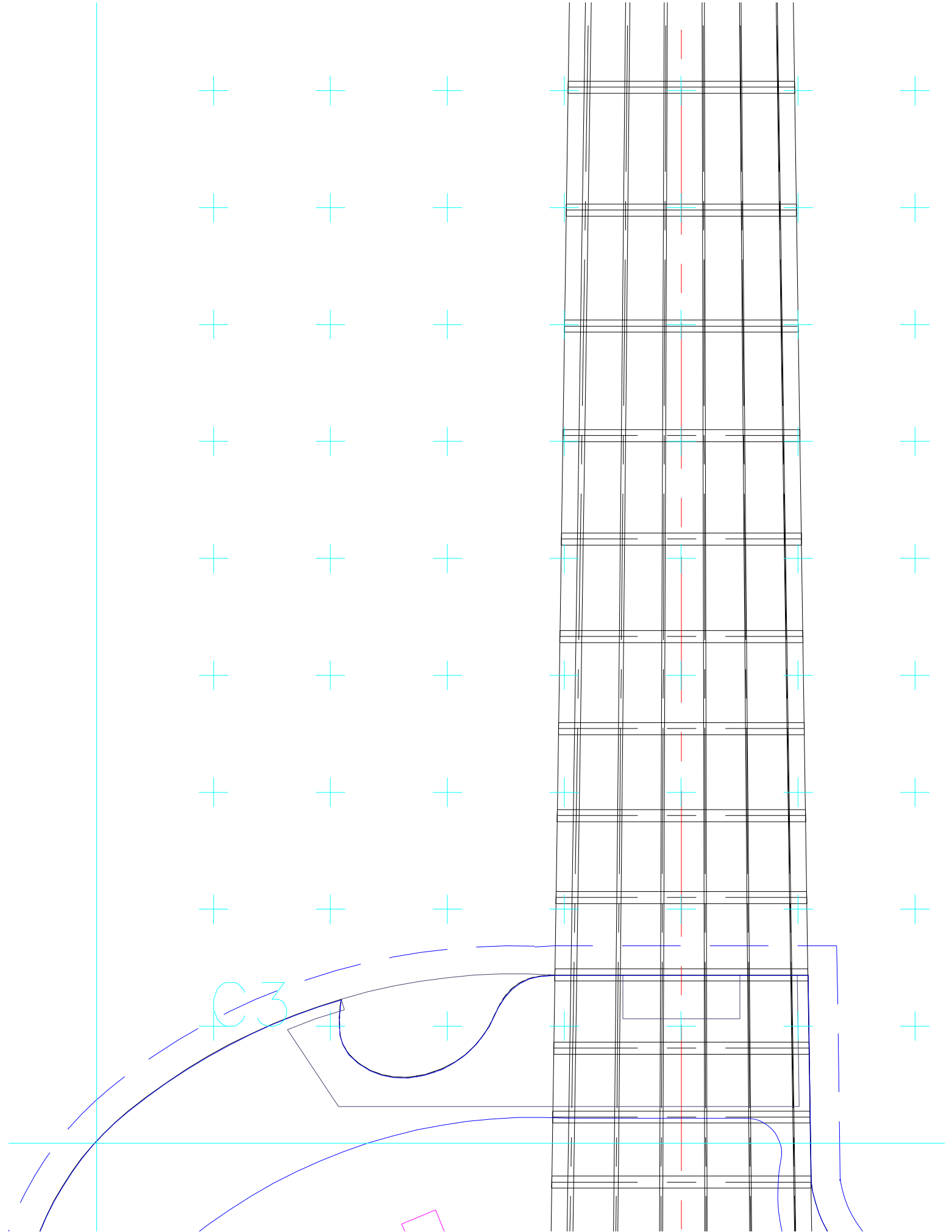

as a cut into the ex
neck block. If the n
is not required a str
width neck block can

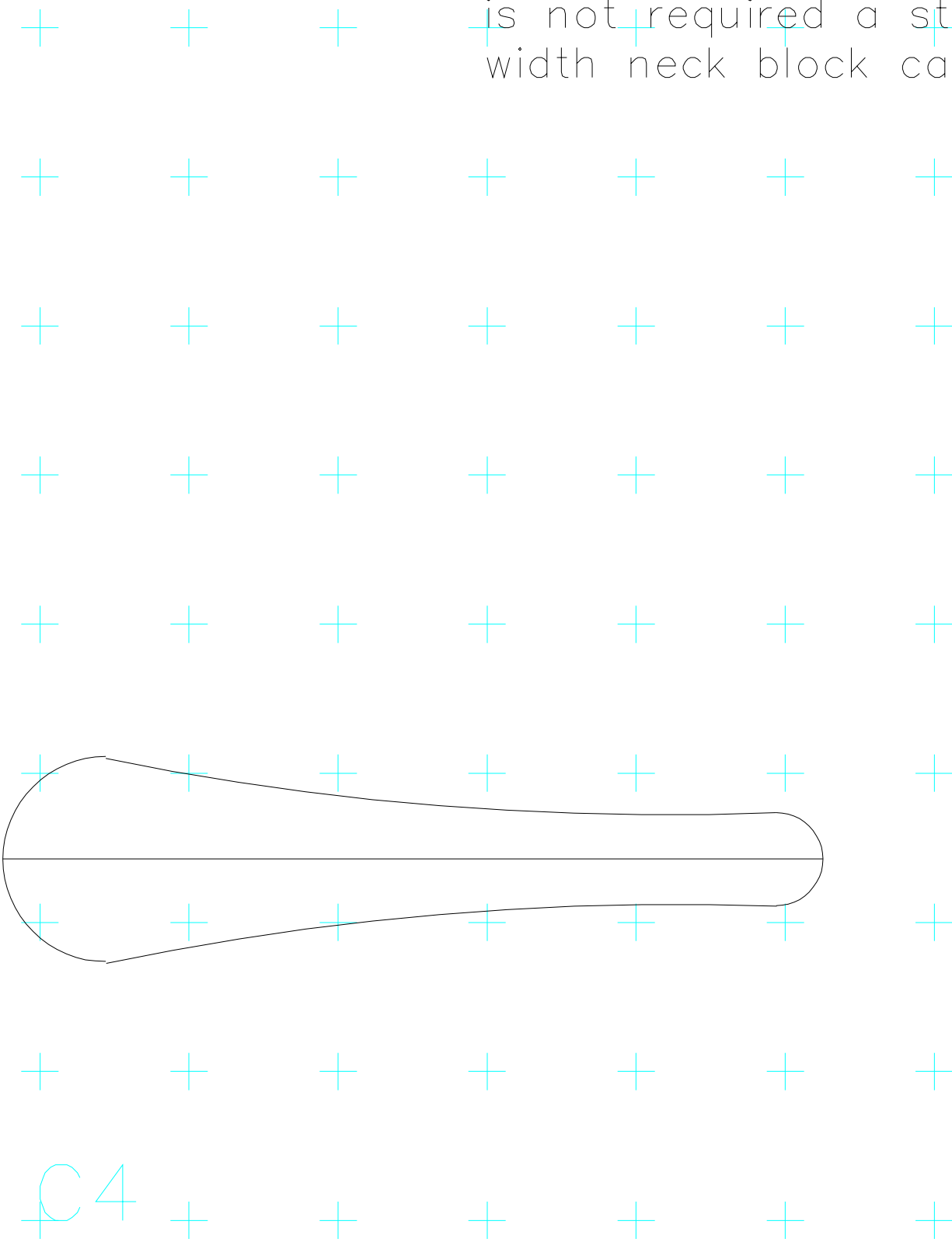

C4

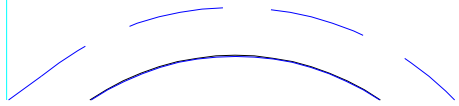

...
mini cutaway
standard
be used.



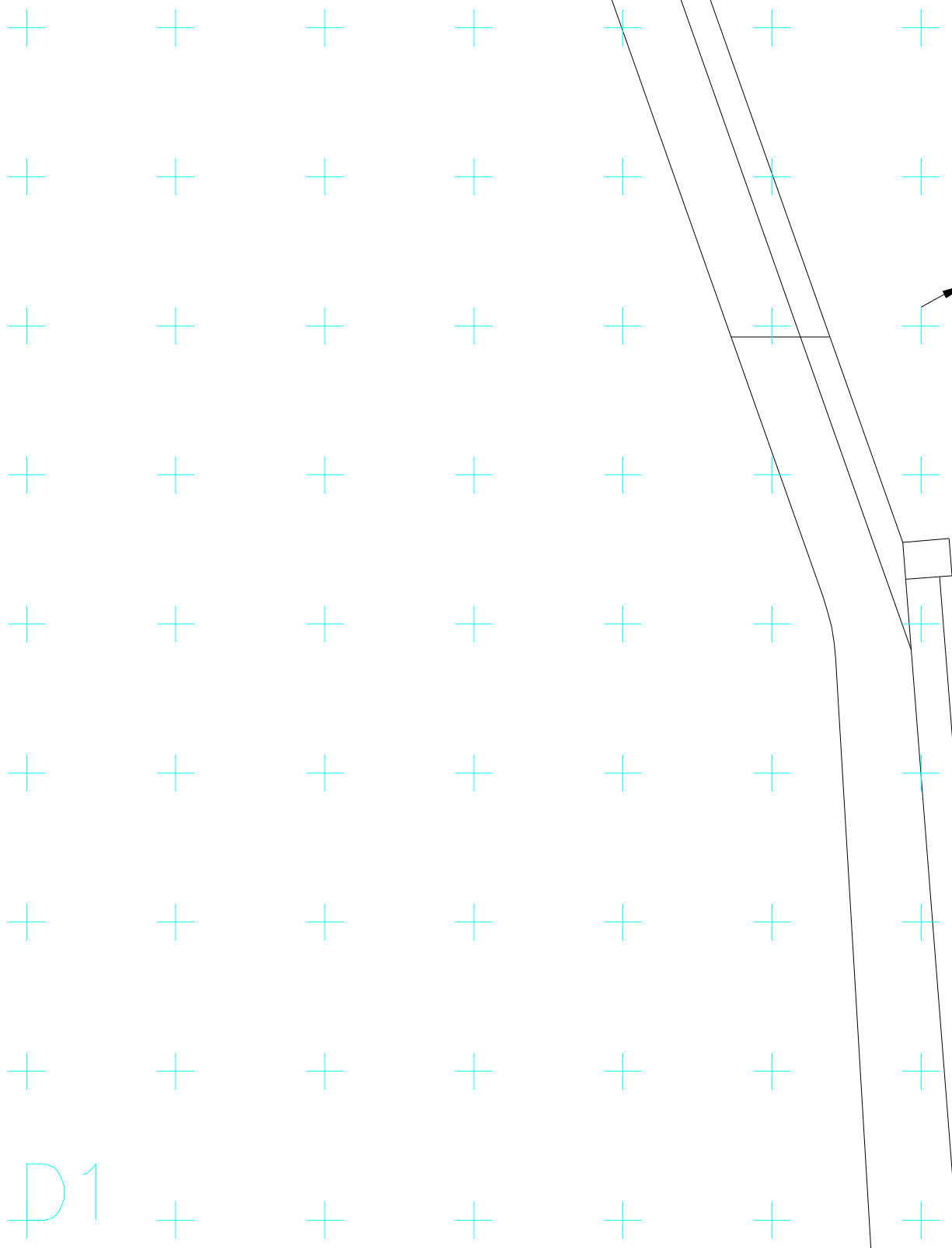

D1

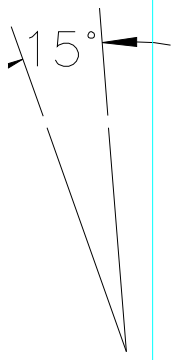
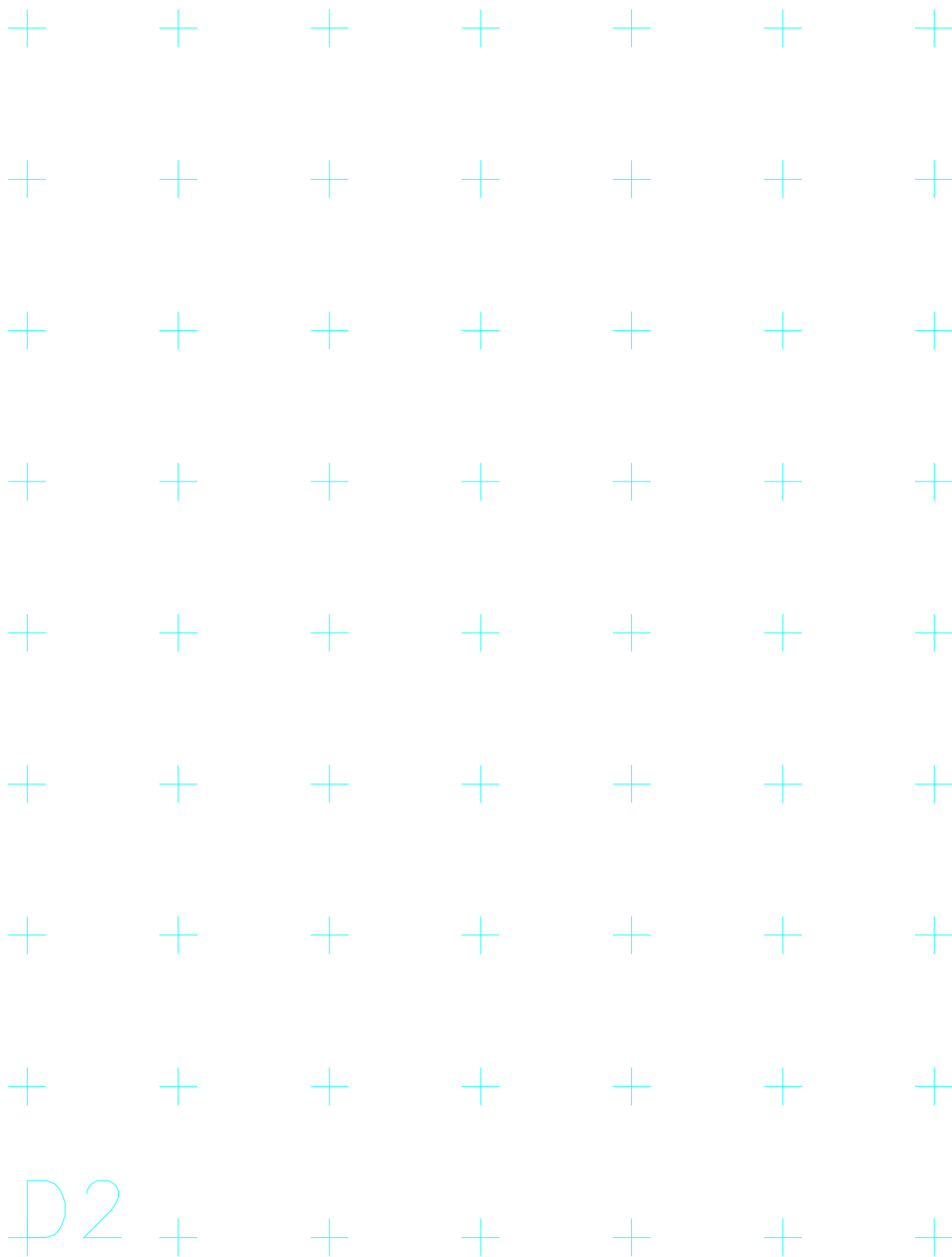

D2

D3

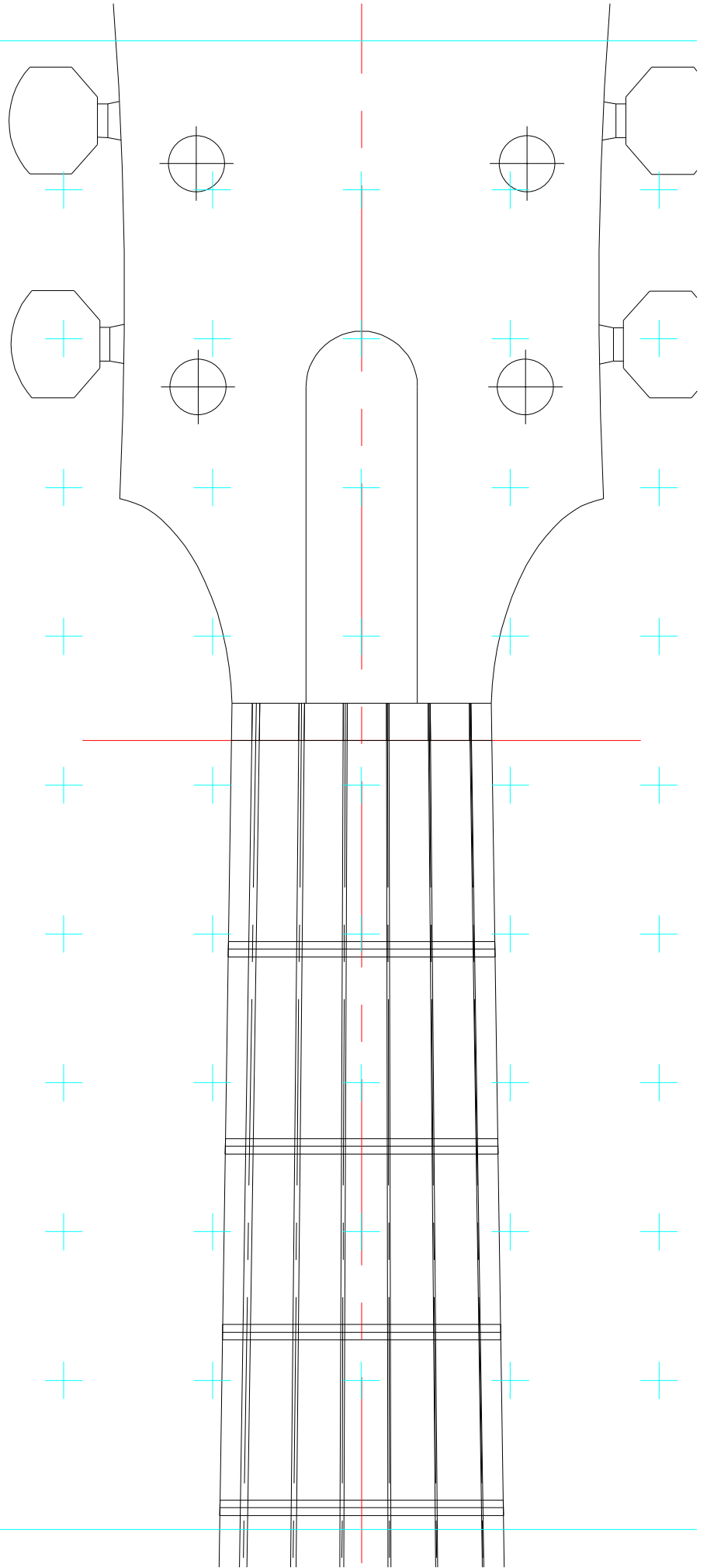

Print Grid
Dimensions
Reference Line:
Hardware
BracesFHole

Scale: 1:1

Copyright (c) 2003 R.I
This plan is made available for non-comme
redistributed. If this plan is obtained from a
LiutaioMottola.com it has been copied in vi

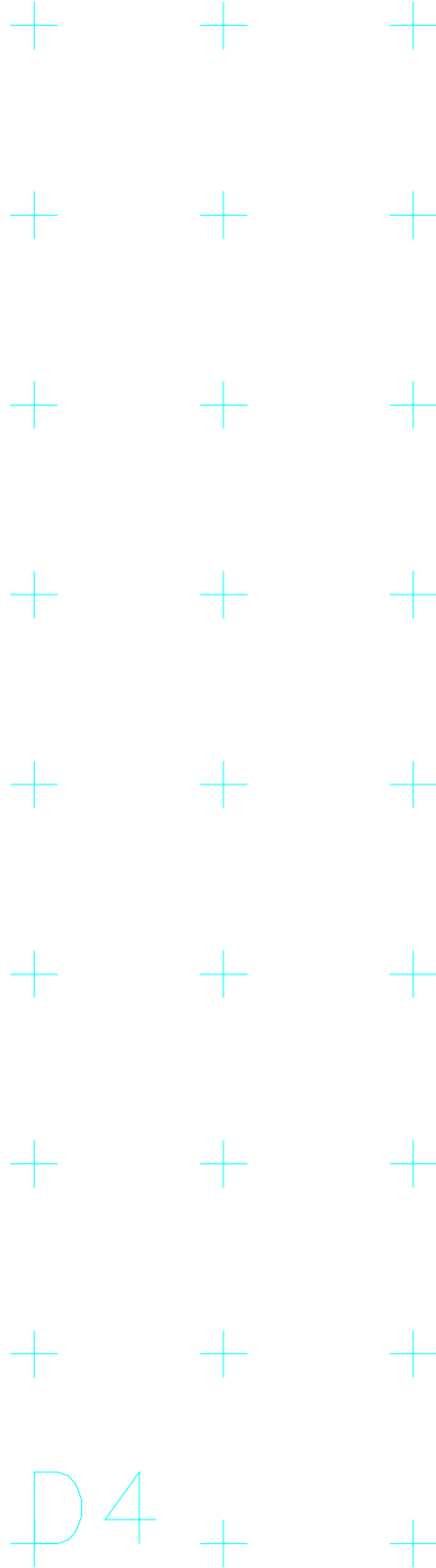

NOTES:

1. Headstock, finger tailpiece in top view shown as if rotated the drawing plane.
2. Round hole and versions are available on appropriate hole & bracing layers.
3. Mini cutaway is i
as a cut into the ov

S

Strings
Titleblock
FHole

Sheet 1 of 1

M. Mottola

For internal use only and may not be
reproduced by any source other than
the original author without the author's
written permission. Violation of copyright.

board, and
drawing are
parallel to

F hole
Turn
and top

implemented
extended

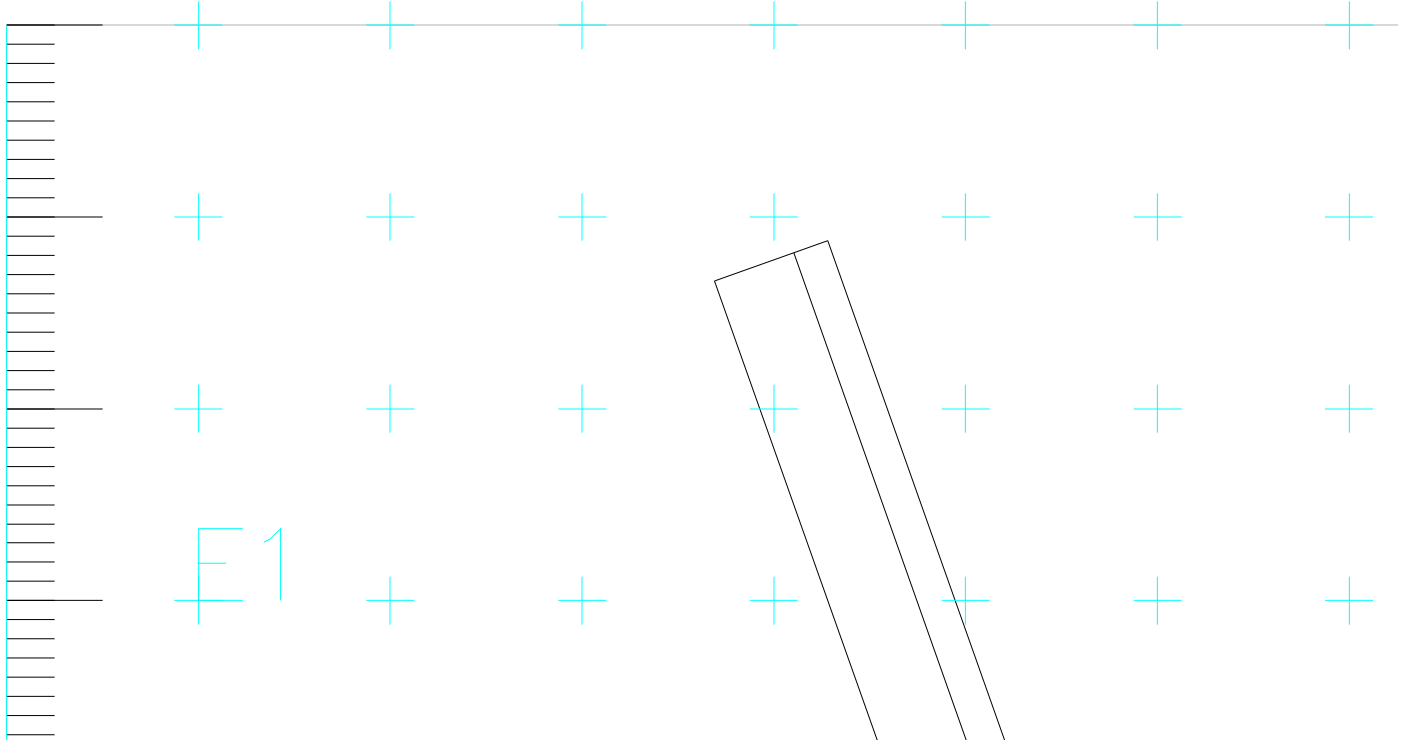

E1



F3

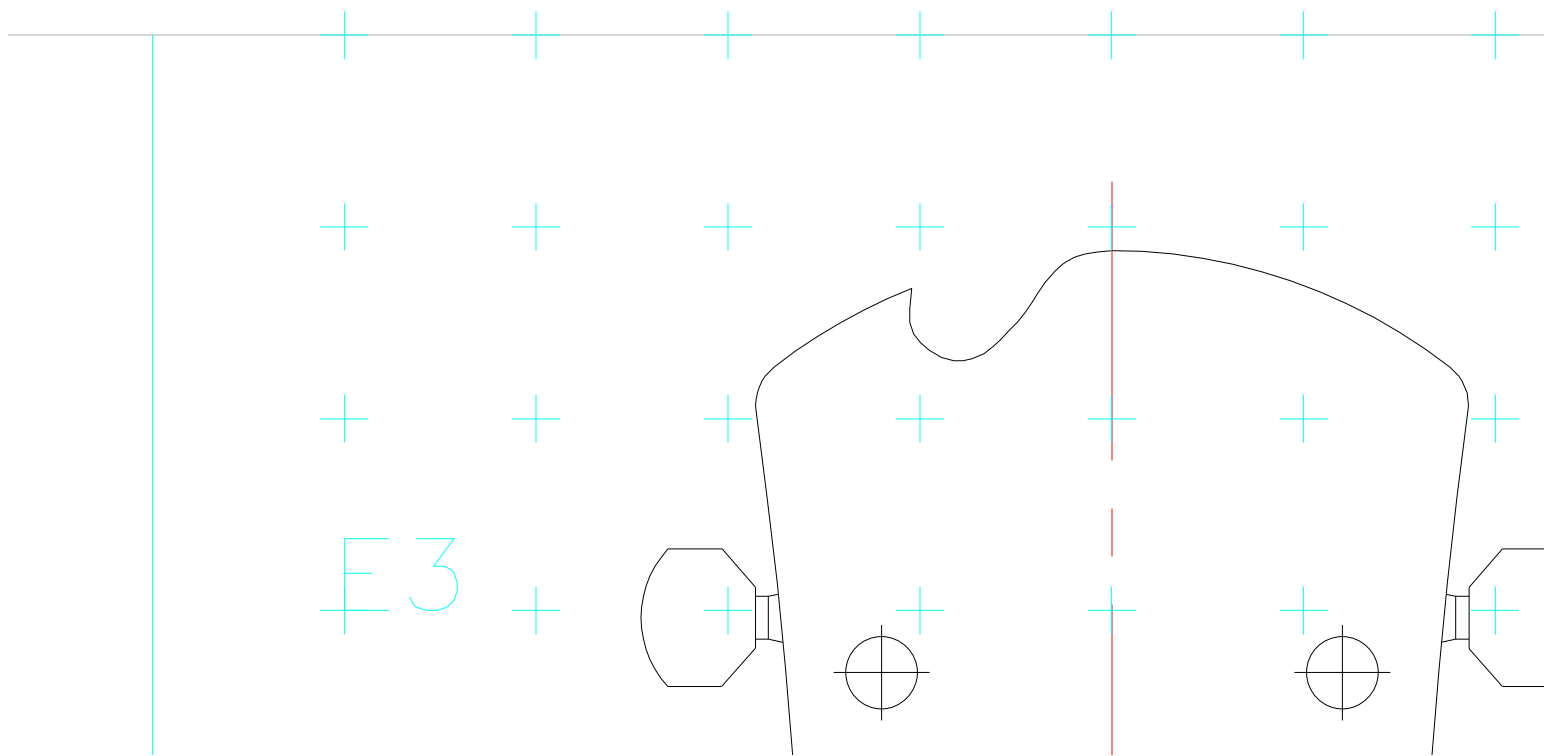

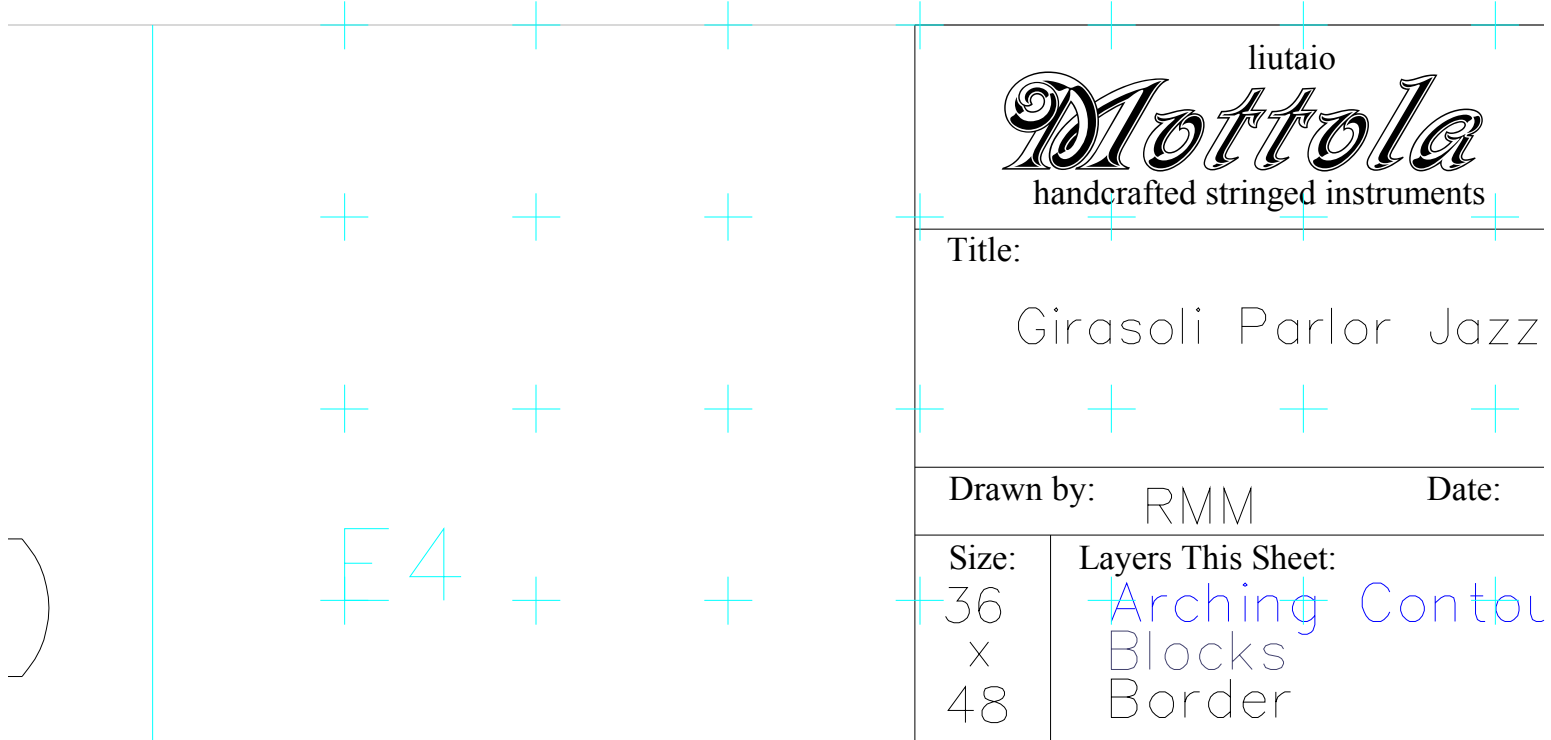

liutaio

Mottola

handcrafted stringed instruments

Title:

Girasoli Parlor Jazz

Drawn by: RMM

Date:

Size:
36
x
48

Layers This Sheet:
Archiving Contbu
Blocks
Border

E4

)

<http://www.LiutaioMottola.com>

Guitar

7/15/03

ur

Neck |
Body
Notes