

A2

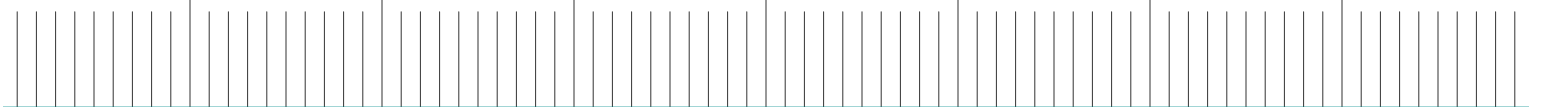

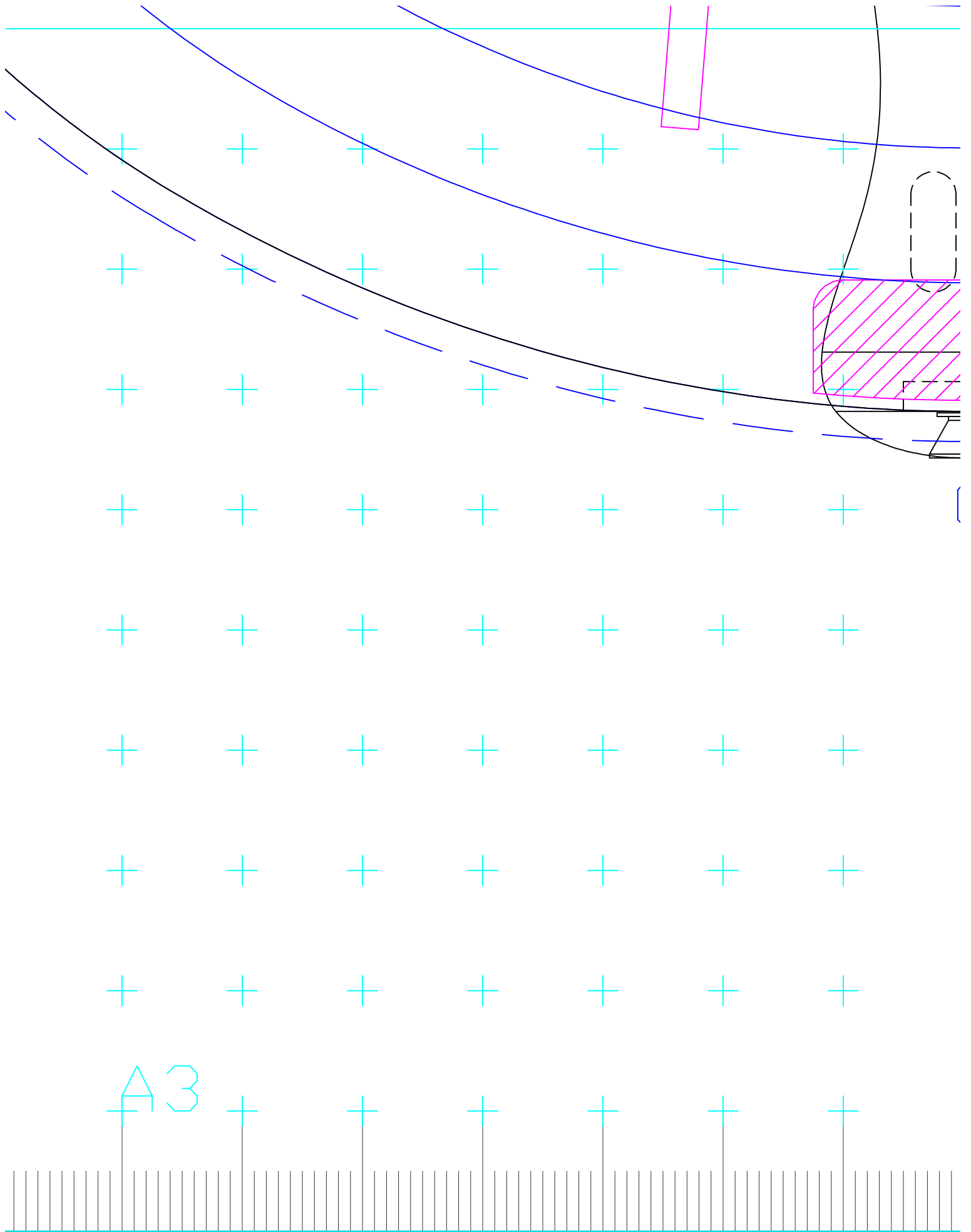

A3

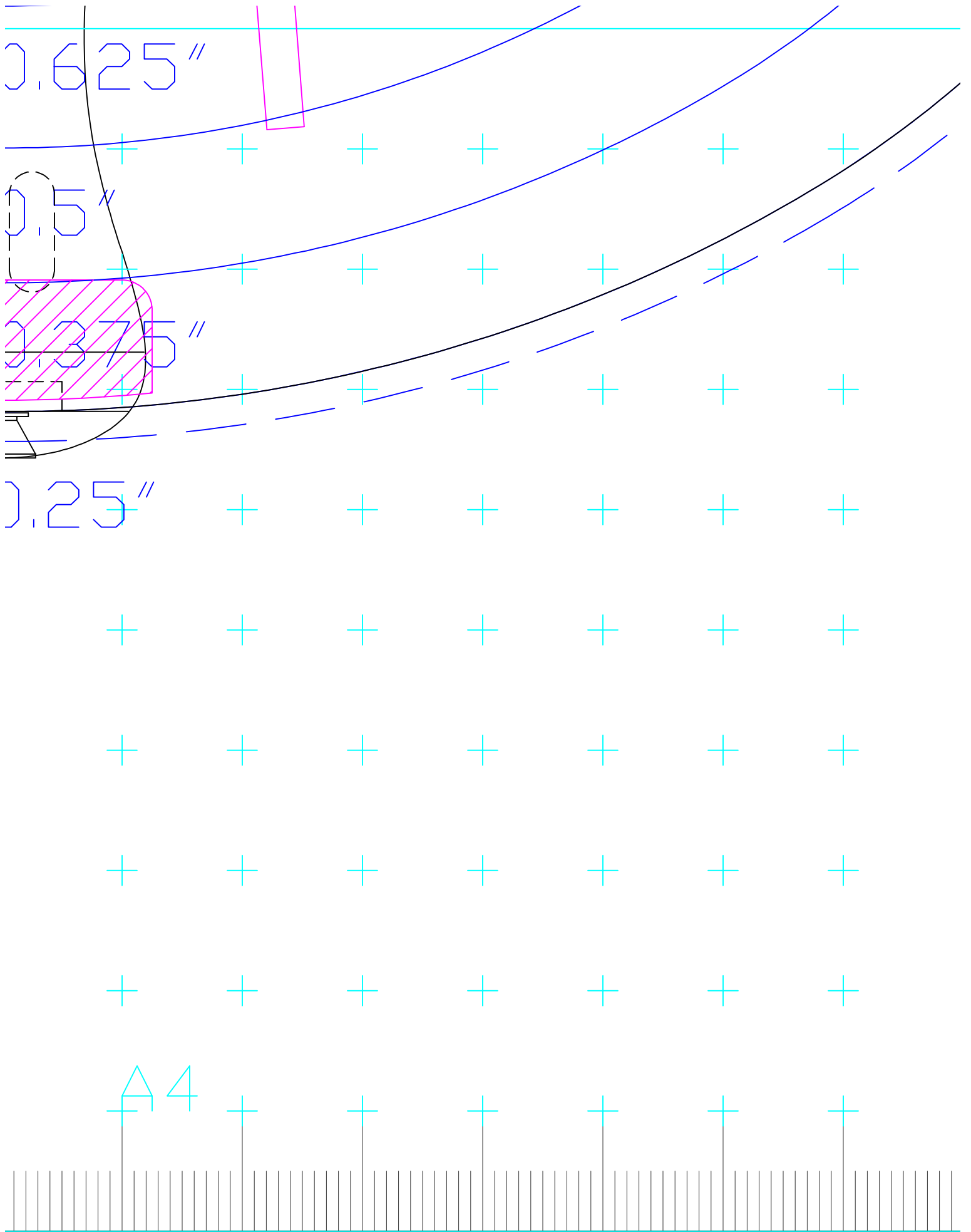

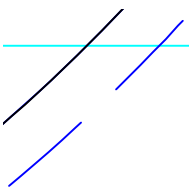

+

+

+

+

+

+

+

+

A5

+

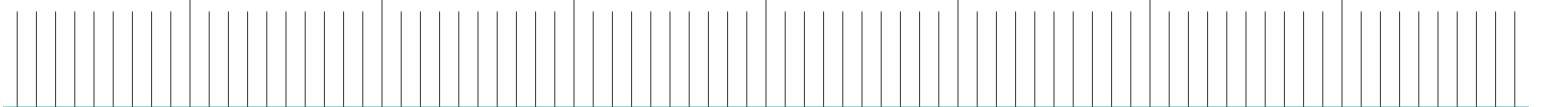

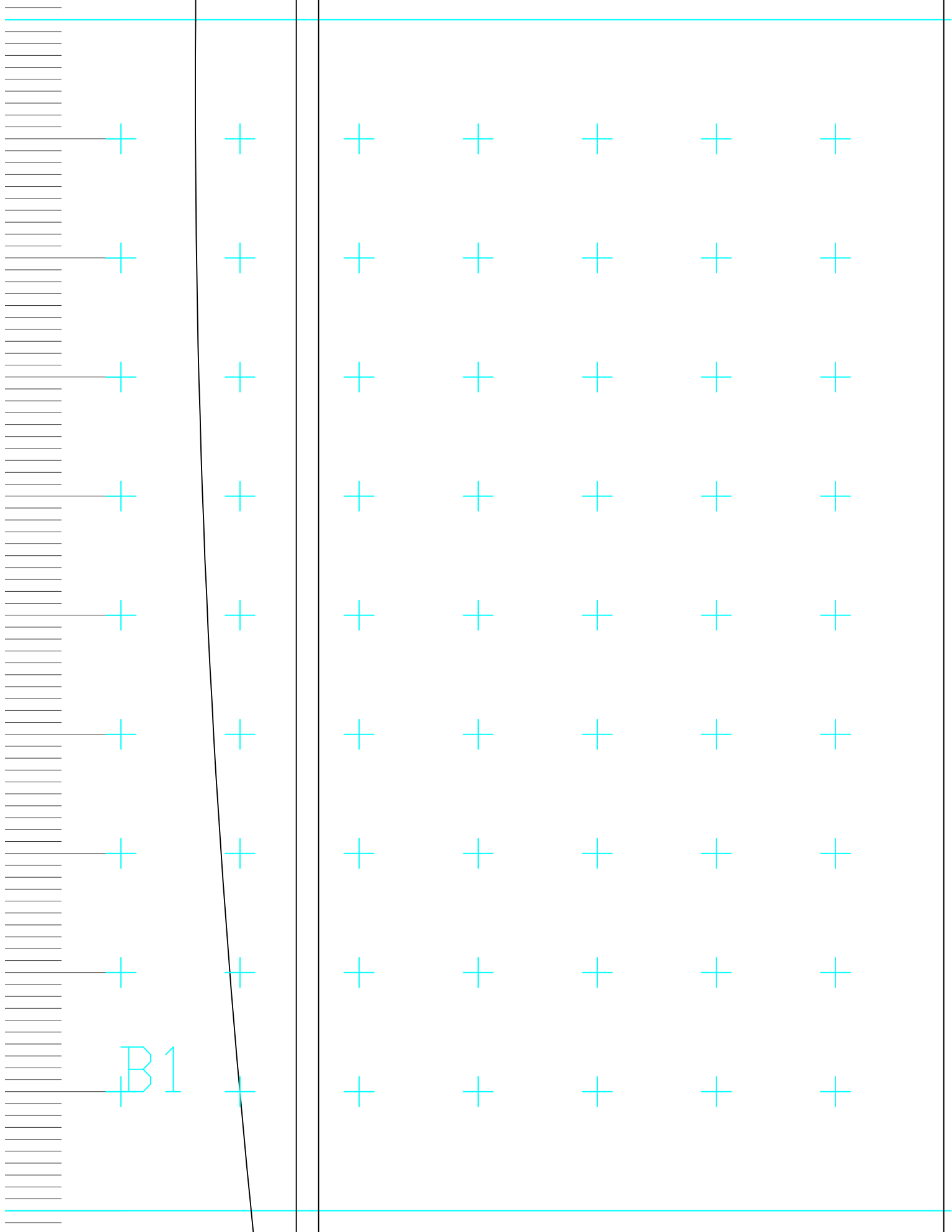

B1

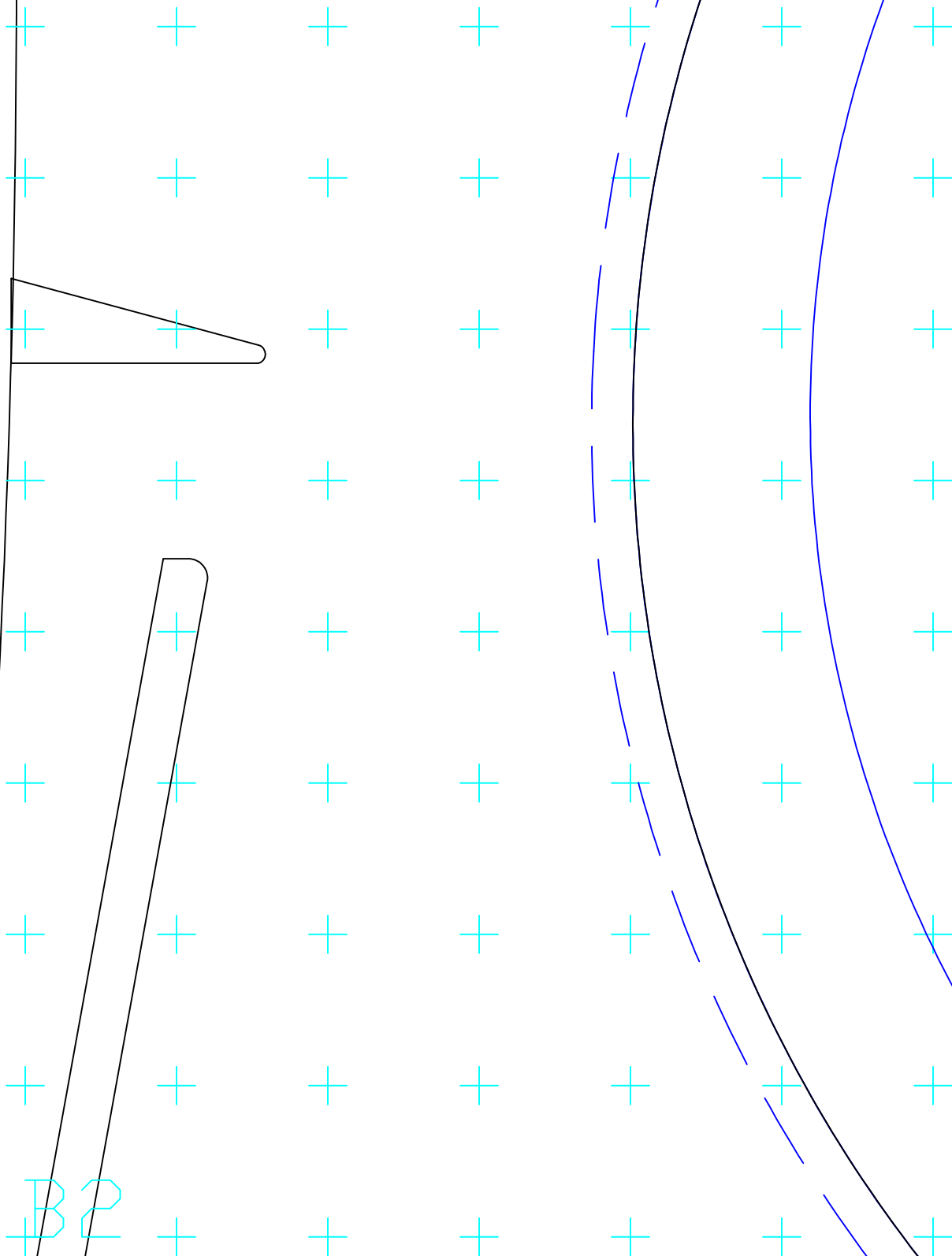

B2

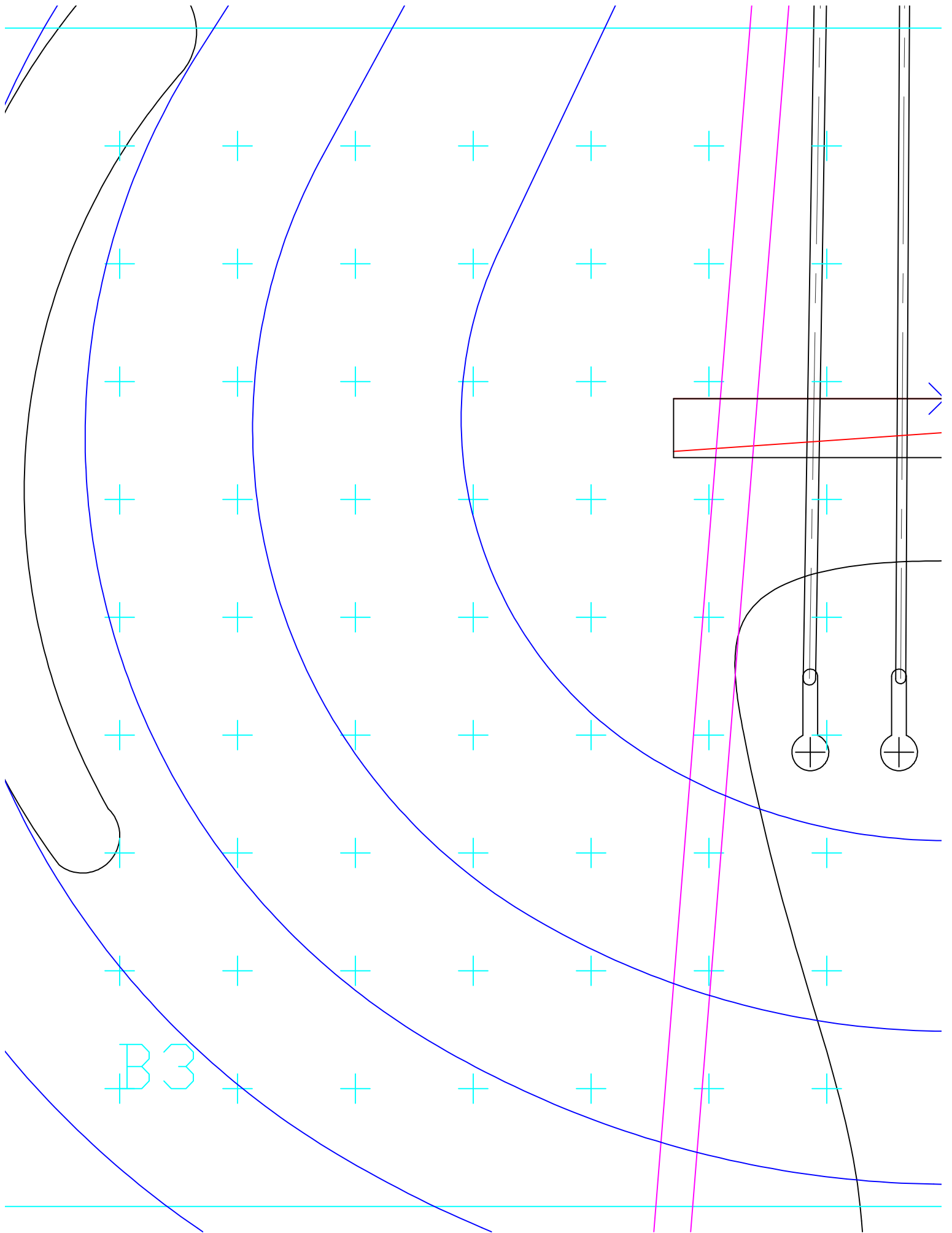

B3

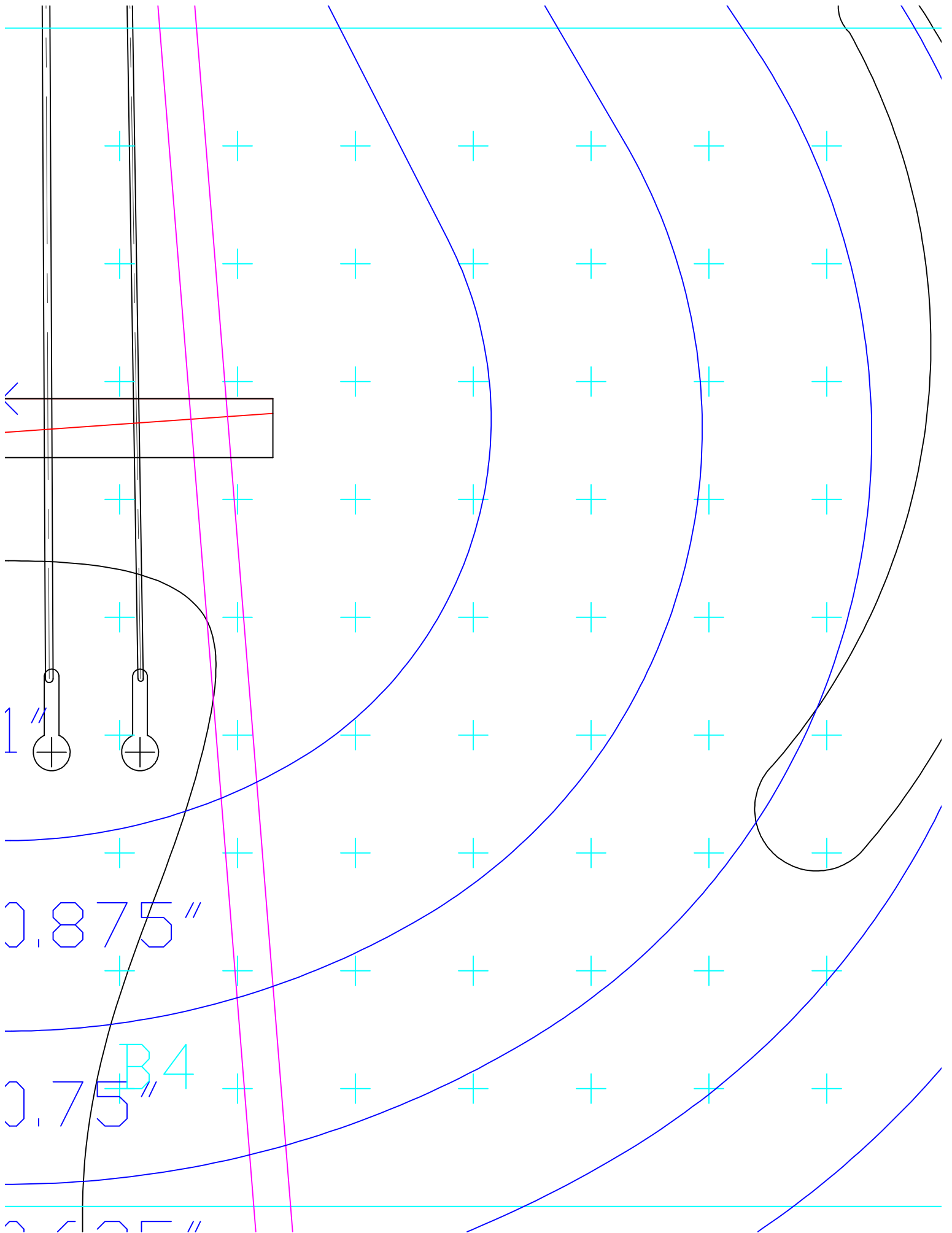

1"

0.875"

0.75" B4

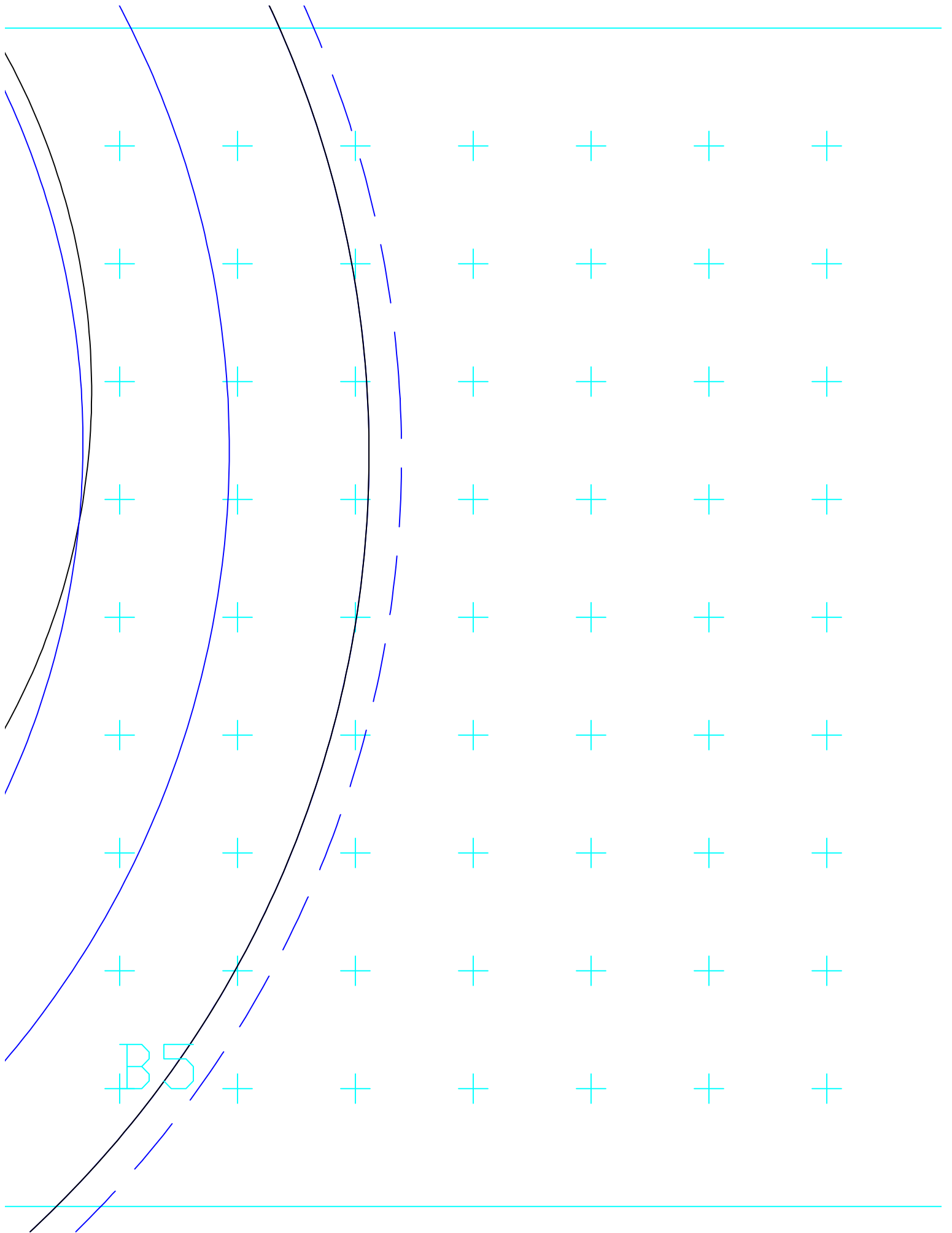

B5

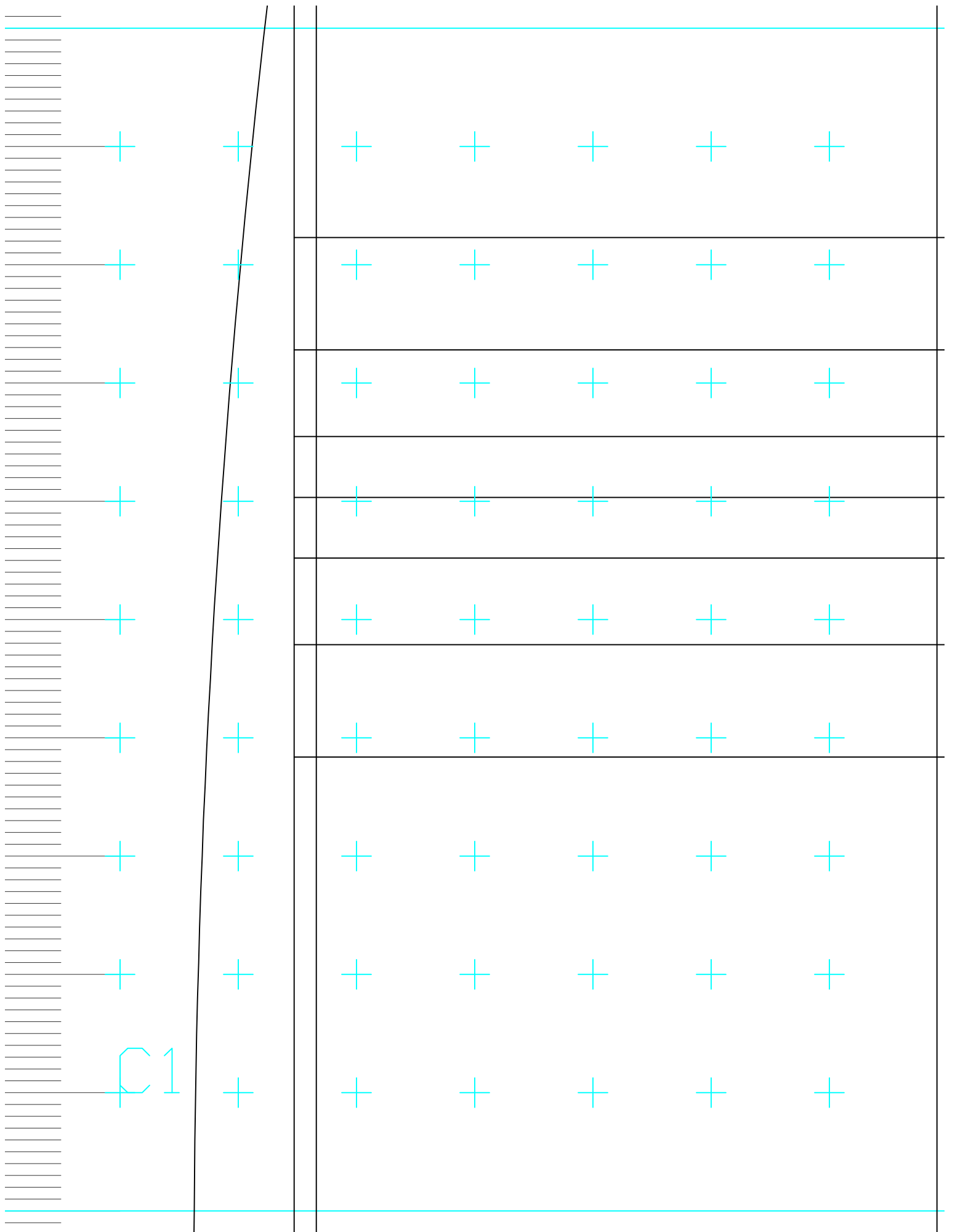

C1

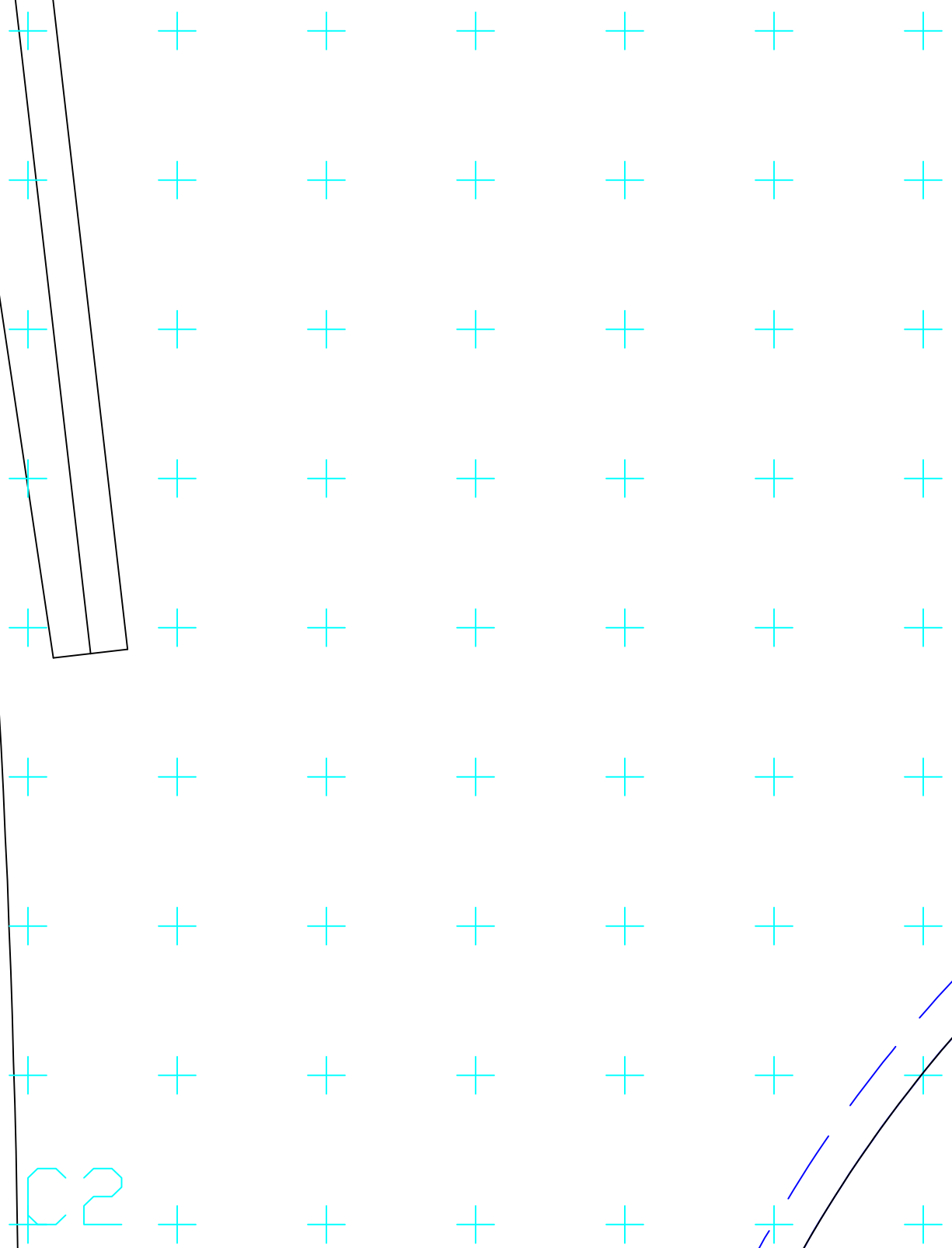

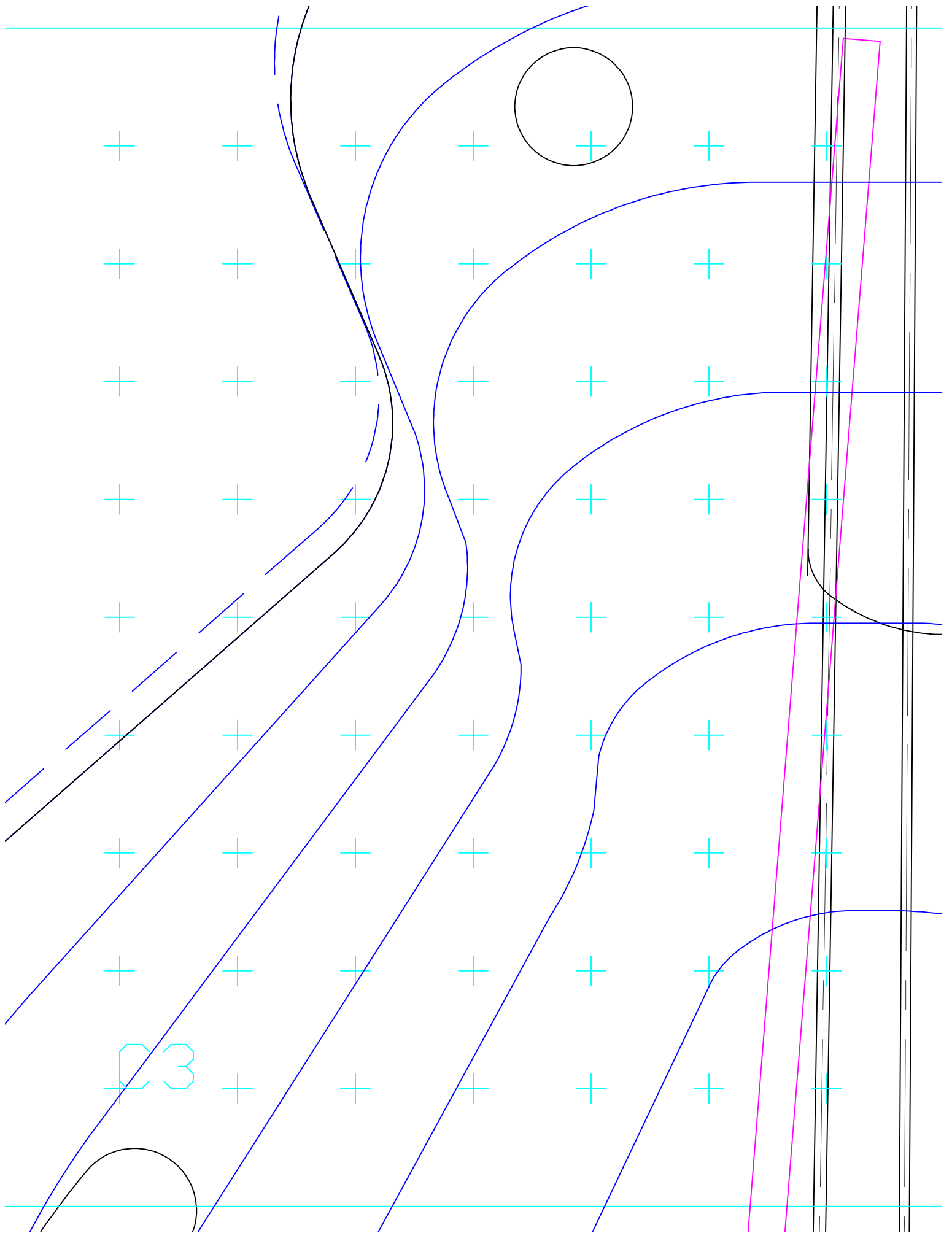

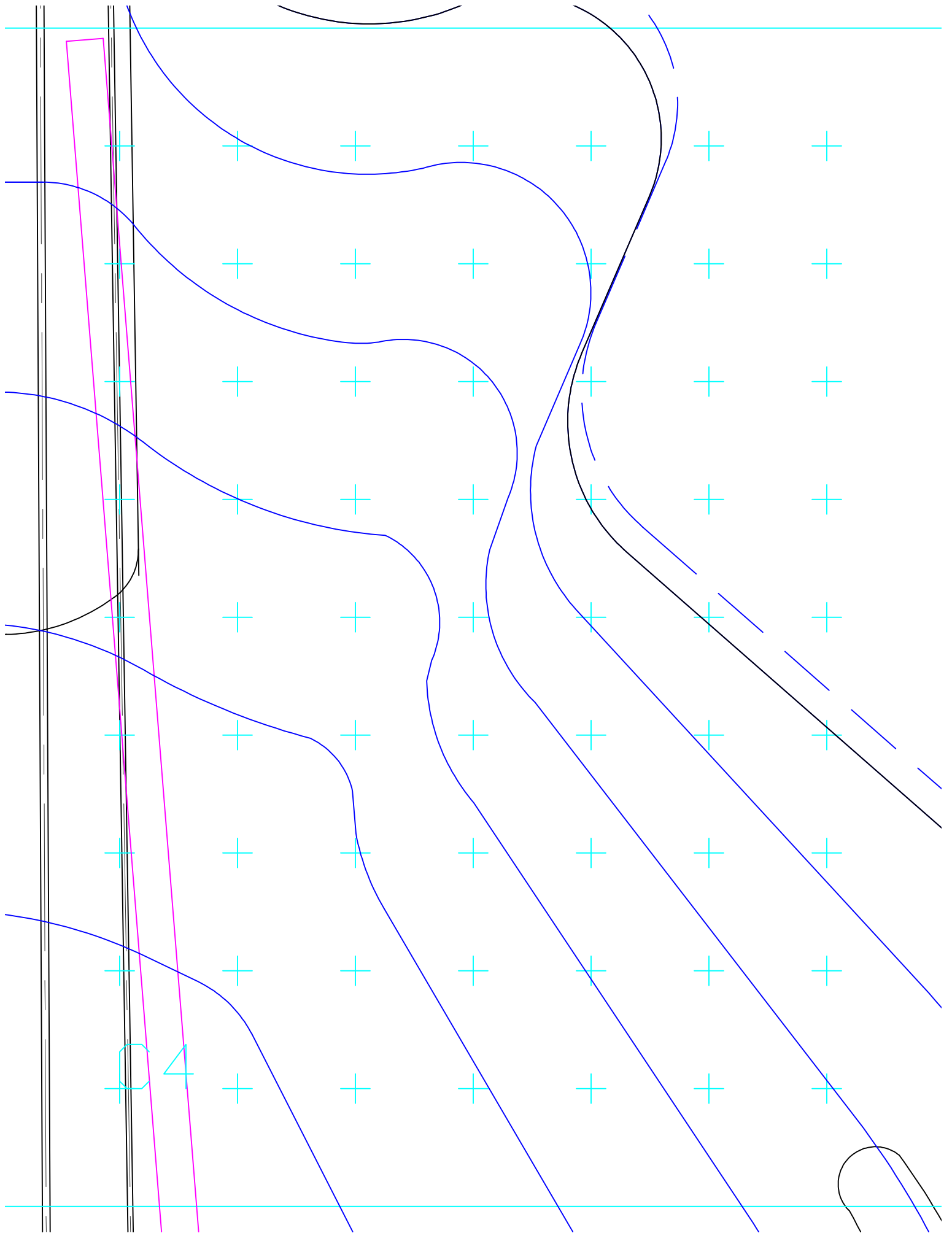

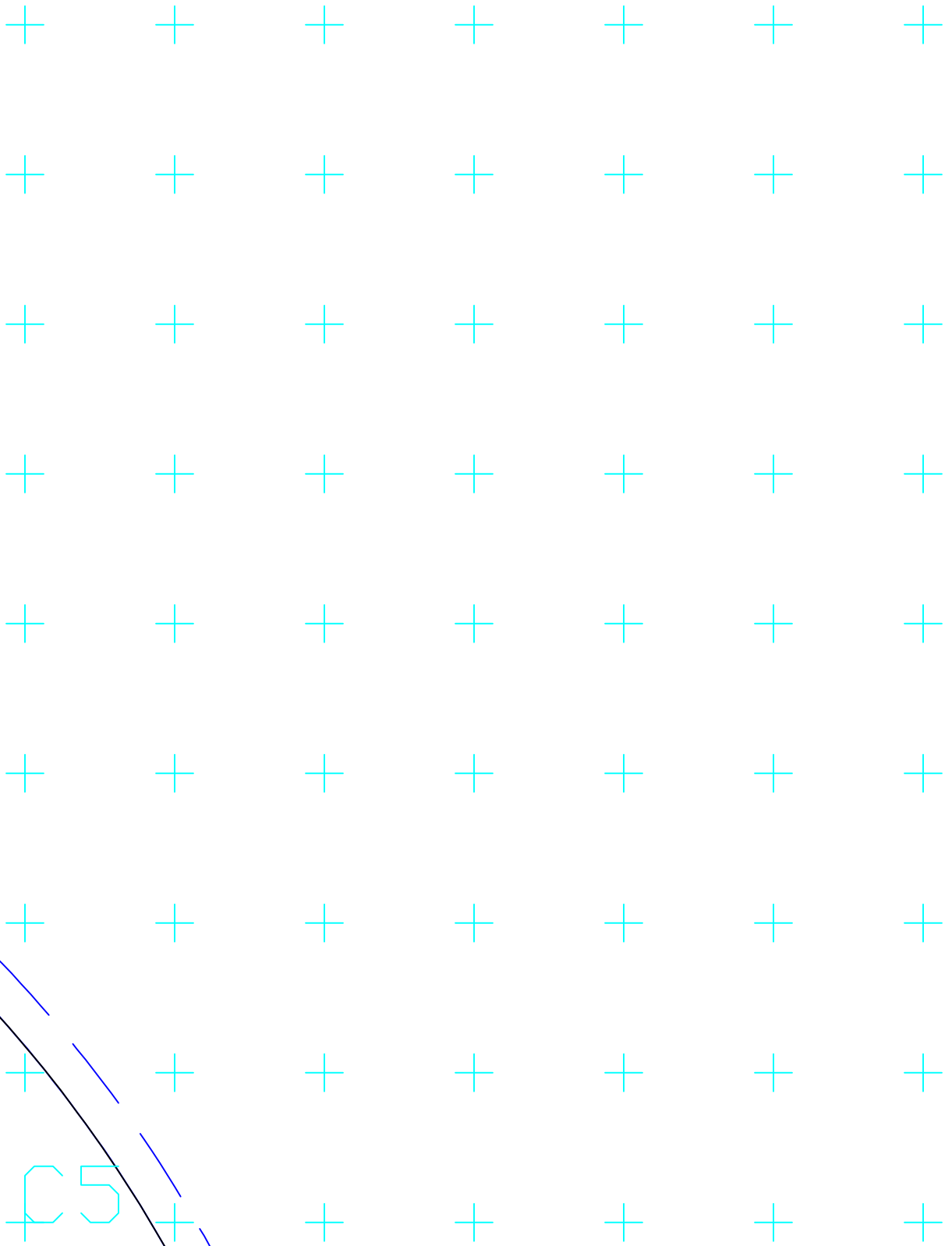

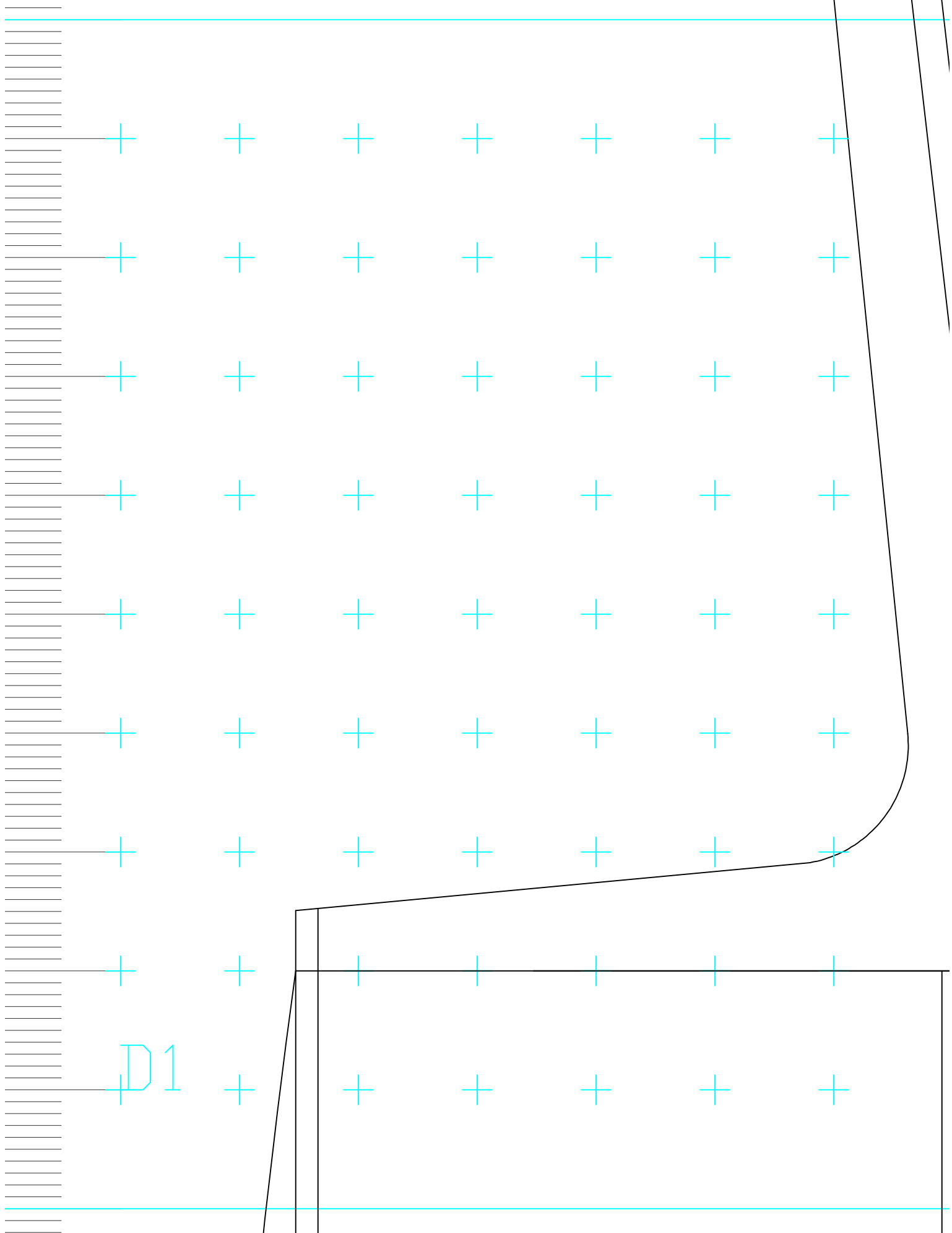

D1

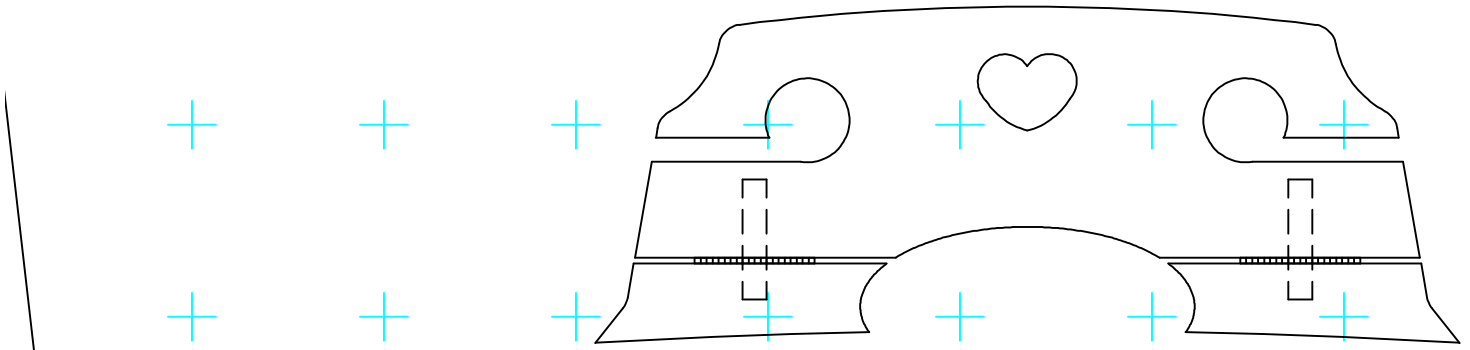

6.5550°

D2

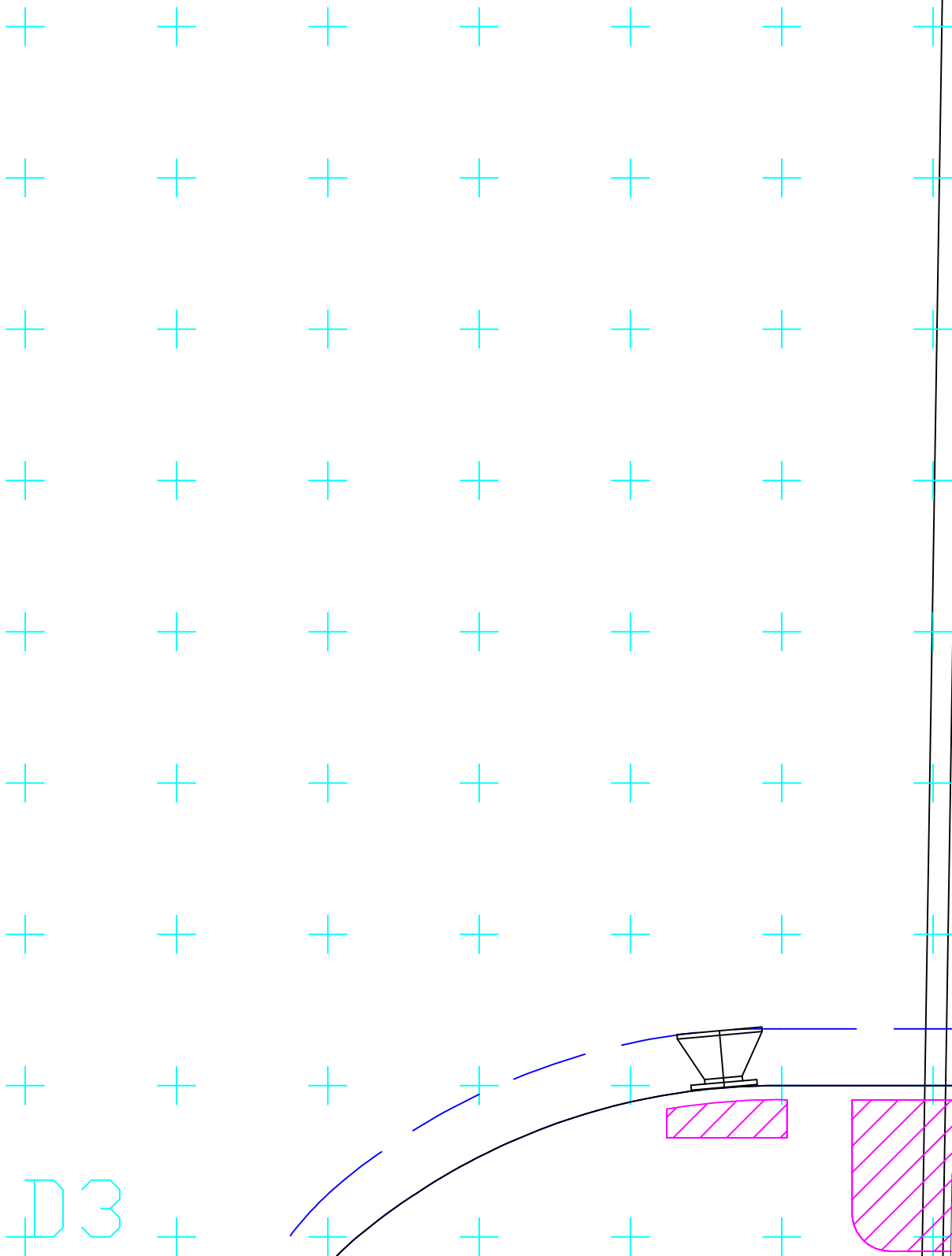

D3

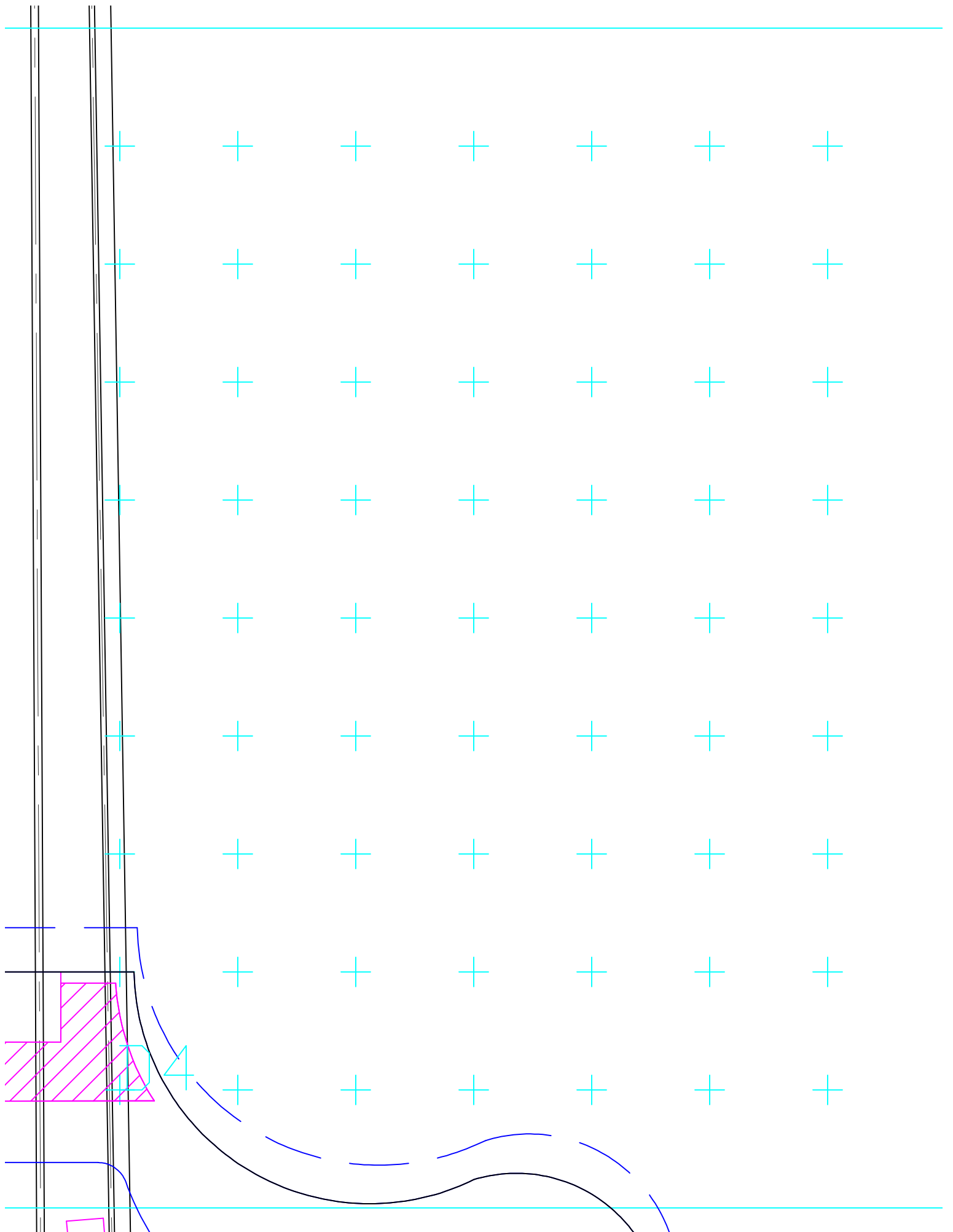

+ + + + + + +

+ + + + + + +

+ + + + + + +

+ + + + + + +

+ + + + + + +

+ + + + + + +

+ + + + + + +

+ + + + + + +

45 + + + + + + +

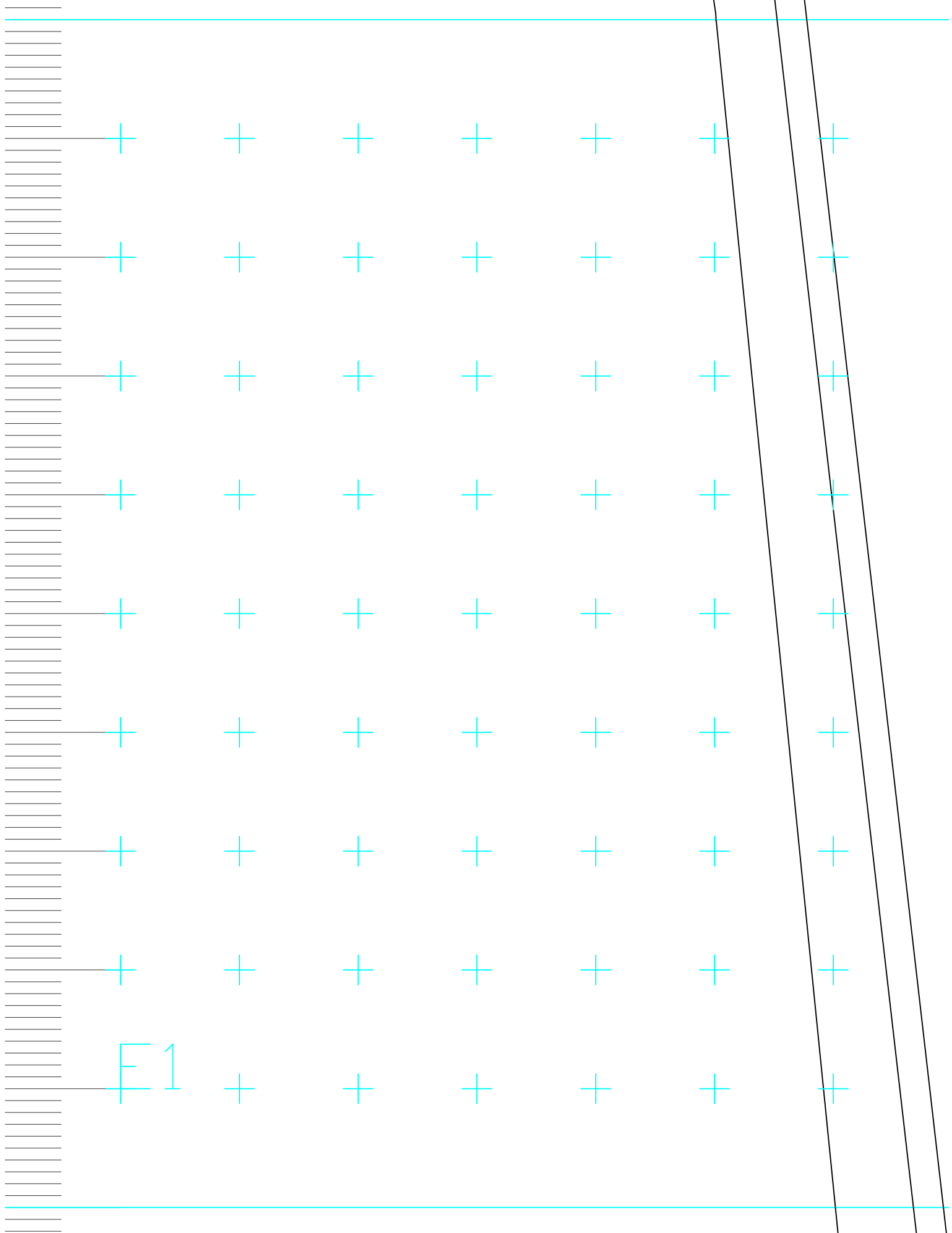

E 1

+ + + + + + +

+ + + + + + +

+ + + + + + +

+ + + + + + +

+ + + + + + +

+ + + + + + +

+ + + + + + +

+ + + + + + +

F2 + + + + + + +

+ + + + + + +

+ + + + + + +

+ + + + + + +

+ + + + + + +

+ + + + + + +

+ + + + + + +

+ + + + + + +

+ + + + + + +

F3 + + + + + + +

+ + + + + + +

+ + + + + + +

+ + + Notes + +

+ + + 1. Headstoc
+ + + tailpiece are
+ + + parallel to t
+ + + the top view

+ + + + + + +

+ + + + + + +

F 4 + + + + + + +

+ + + + + + +

+ + + + + + +

+ + + + + + +

<, fingerboard, and
drawn as if rotated
the drawing plane in
drawing.

+ + + + + + +

+ + + + + + +

F5 + + + + + + +

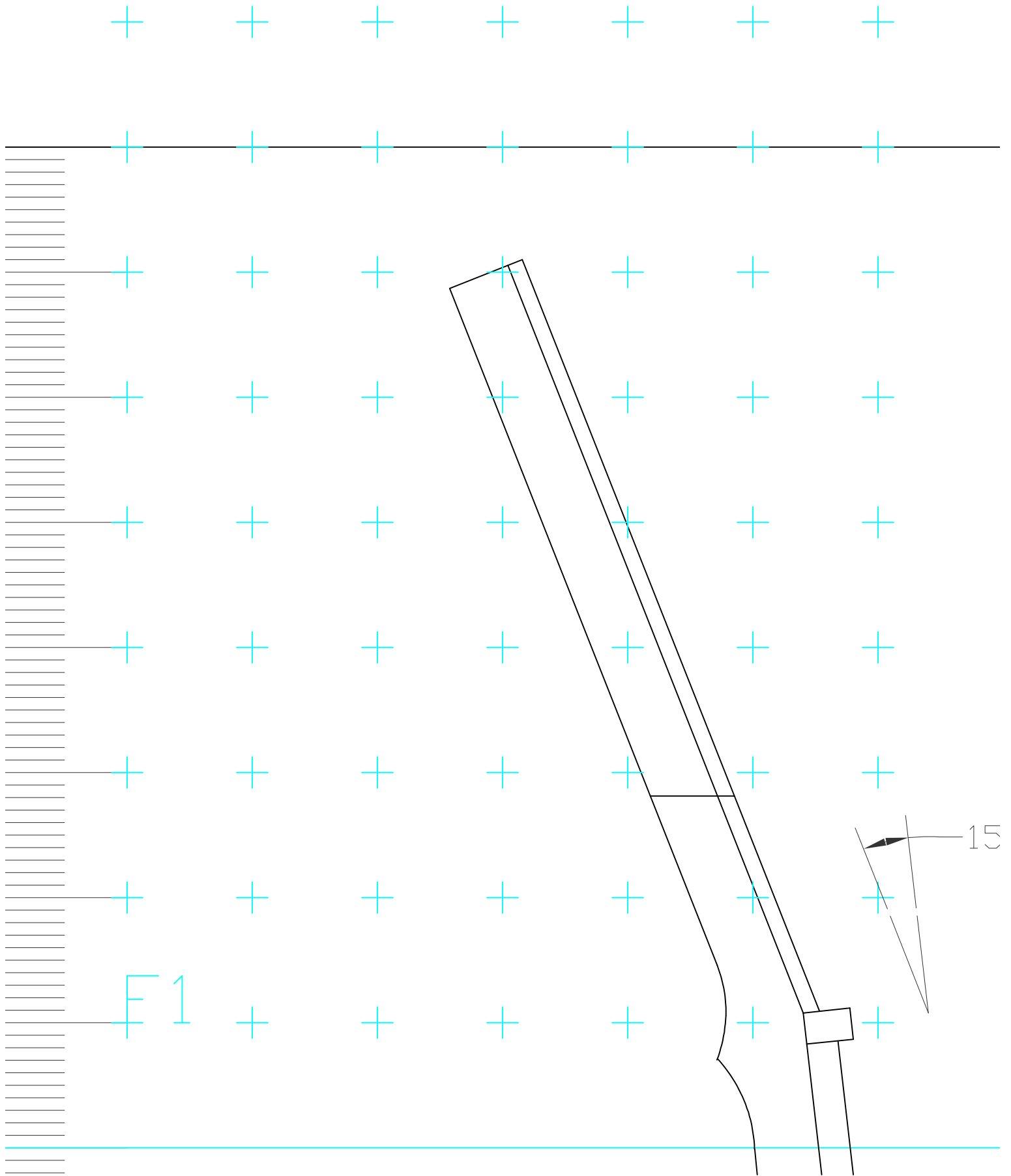

+ + + + + + +

+ + + + + + +

+ + + + + + +

+ + + + + + +

+ + + + + + +

+ + + + + + +

+ + + + + + +

,0000°

+ + + + + + +

F2 + + + + + + +

+ + + + + + +

+ + + + + + +

+ + + + + + +

+ + + + + + +

+ + + + + + +

+ + + + + + +

+ + + + + + +

+ + + + + + +

F3 + + + + + + +

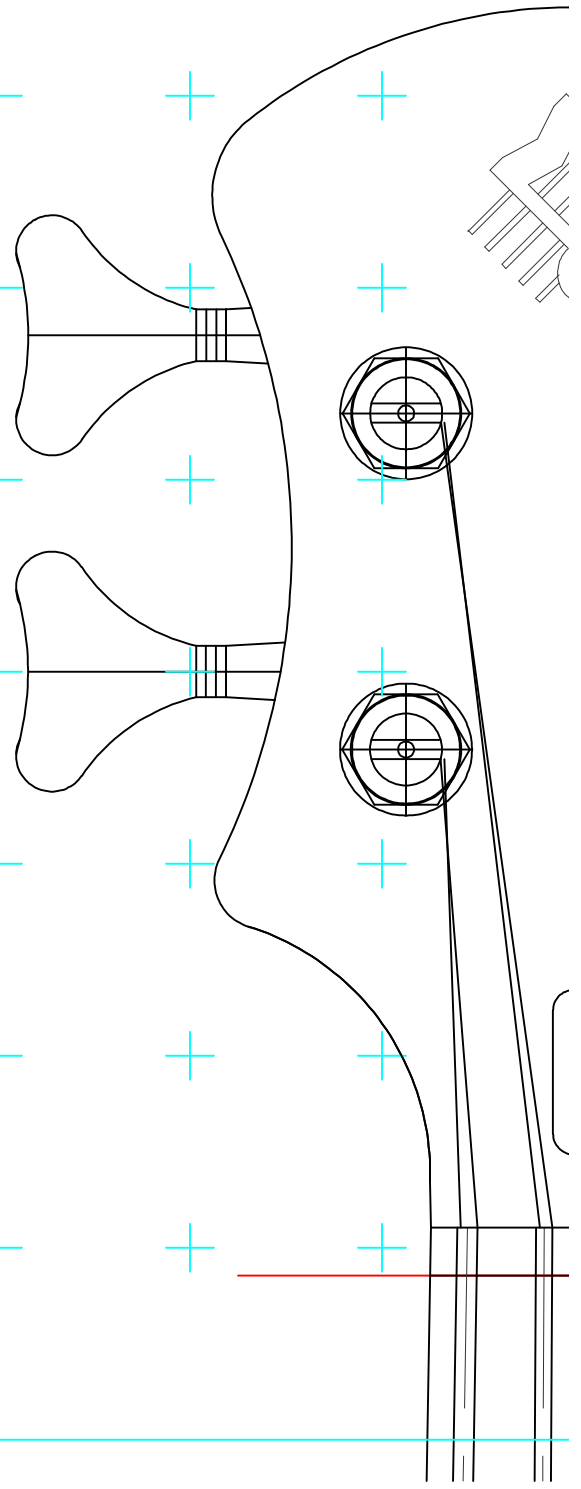

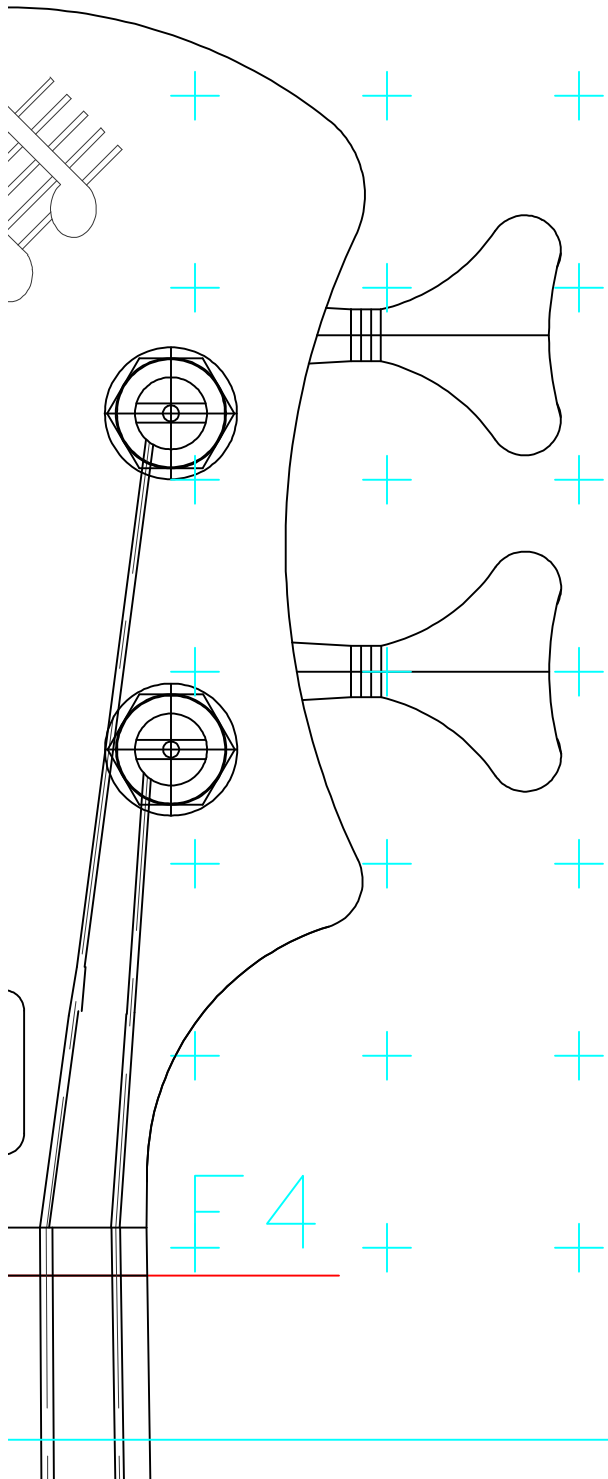

F4

liuta
Motiv
handcrafted stringed

Title:

Uccello G

Drawn by:

RMM

Code Ident No:

S
Z
E

Scale:

to fit

io

Liutaio Mottola

instruments

rm@LiutaioMottola.com

Masso Acoustic Bass

Date:

4/14/02

Size:

2

X

50

Drawing No:

F5

Sheet

1

of

1